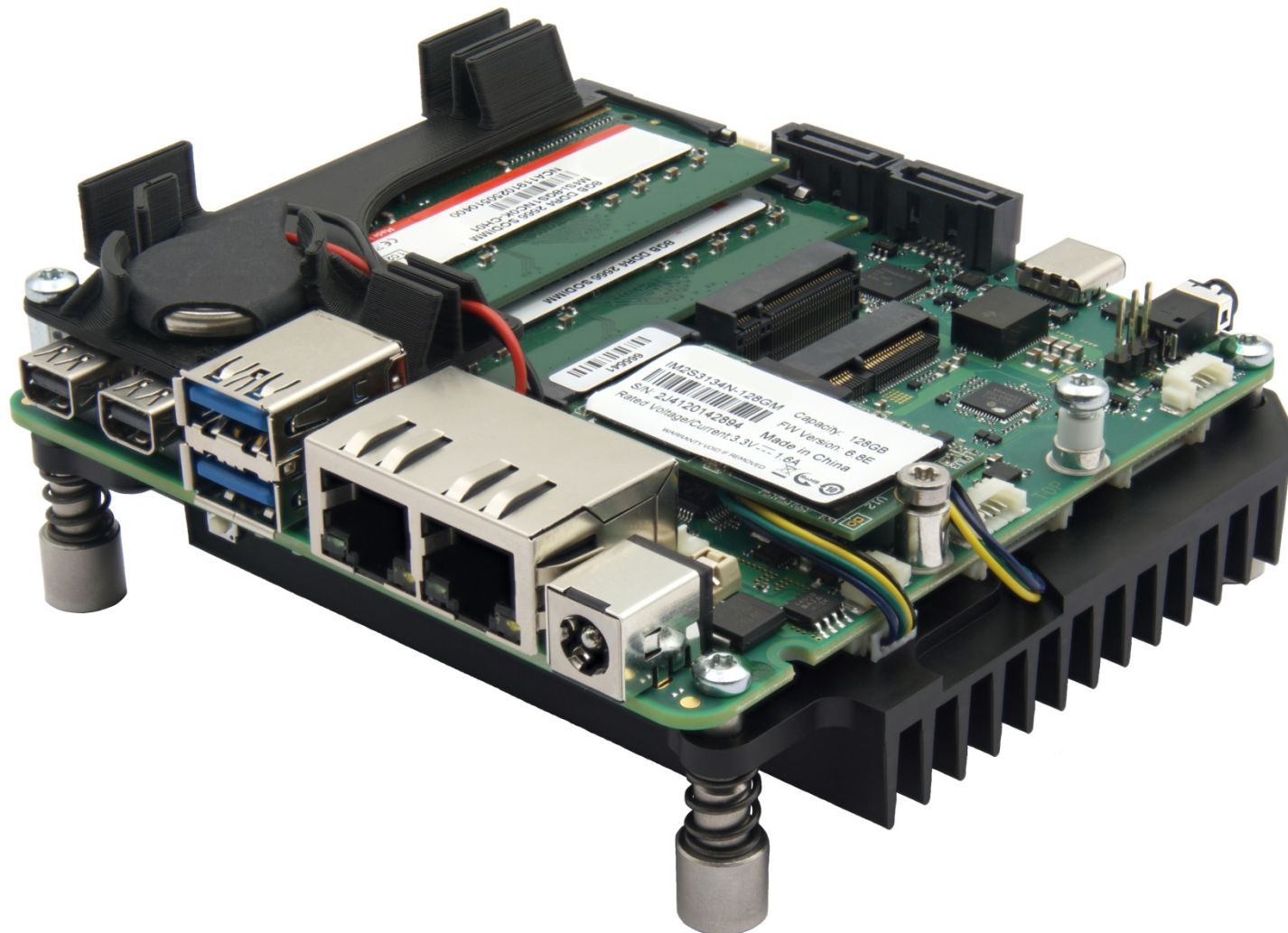


# PROFIVE® NUCE\_C 25 W – Hardware Reference Manual – P – Rev. 1

---



## Manufacturer

E.E.P.D. Electronic Equipment Produktion & Distribution GmbH  
Gewerbering 3  
85258 Weichs

Phone: +49 8136 2282 – 0  
Fax: +49 8136 2282 – 109  
Web: <https://www.eepd.de>  
E-Mail: [sales@eepd.de](mailto:sales@eepd.de)

## General Notes

This user manual is for your information.

The information contained herein has been checked carefully and is believed to be reliable. However, E.E.P.D. GmbH gives no guarantee or warranty concerning the accuracy of spoken information and shall not be responsible for any loss or damage of any nature resulting from the usage of or from reliance upon it.

We are thankful for all suggestions or improvements at any time.

**E.E.P.D. GmbH reserves the right to make changes in the products or specifications, or both, at any time without notice.**

10/2021 Revision 1.7

E.E.P.D. GmbH | Gewerbering 3 | 85258 Weichs

Copyright ©2020|2021 E.E.P.D. GmbH.  
All rights reserved.  
10/2021 Revision 1.7

## Copyright Notice

Copyright© 2020|2021 E.E.P.D. GmbH. ALL RIGHTS RESERVED!

E.E.P.D. GmbH copyrights this document. You may not reproduce, transmit, transcribe, store in a retrieval system, or translate into any language, in any form or by any means, or otherwise, any part of this publication without the express written permission of E.E.P.D. GmbH.

## Trademark Acknowledgement

AT, DOS, OS/2, VGA are registered trademarks of International Business Machines Corporation.

Intel, Pentium and Atom are registered trademarks of Intel Corporation.

Panel Link and TMDS are registered trademarks of Silicon Image, Inc.

VESA is a registered trademark of Video Electronics Standard Association.

Windows 10/ 11 is a registered trademark of Microsoft Corporation.

PROFIVE® and E.E.P.D.® are registered trademarks of E.E.P.D. Electronic Equipment Produktion and Distribution GmbH.

**All rights reserved. All other mentioned trademarks are registered trademarks of their owners.**

## Disclaimer

This document is provided for the general information of the customer. It describes the general functionality of the board and is not considered as assured characteristics. The written declarations in this document are not constituent part of any contract.

E.E.P.D. GmbH reserves the right to modify the information contained in this document as necessary and the customer should ensure that he has the most recent revision of this document.

E.E.P.D. GmbH makes no warranty for the use of its products and bears no responsibility for any errors, which may appear in this document. The customer should be on notice that the field of personal computers is the subject of many patents held by different parties. Customer must ensure that they take appropriate action so that their use of the products does not infringe upon any patents. It is the policy of E.E.P.D. GmbH to respect the valid patent rights of third parties and not to infringe upon or assist others to infringe upon such rights.

E.E.P.D. GmbH assumes no responsibility for circuits, descriptions and tables within this document as far as patents or other rights of third parties are concerned.

## Life Support Applications

E.E.P.D. GmbH products are not intended for using as critical components in life support appliances, devices or systems in which the failing of an E.E.P.D. GmbH product could be expected to result in personal injury.

## FCC and CE Disclaimer

This product cannot be used as a stand-alone product!

Therefore, it has to be integrated together with other products like power supplies, mass storage devices (i. e. hard disks), etc. to be functional.

To meet FCC and/or CE requirements every component as well as the combination of all components has to be validated against all standards required for the end product.

In order to meet FCC and/or CE requirements this product has to be integrated into a proper housing, which provides appropriate shielding and insulation.

It is on the customer's sole responsibility to assure that this end-product meets all required standards.

E.E.P.D. GmbH gives no warranty at all that their products will meet the FCC and CE standards when used in combination with other third-party products or when used in any other way than specified.

## Limited Warranty

This product will be free from defects in workmanship and material under normal and proper use for the period of time defined in our General Terms of Business, effective the date of the original shipment from E.E.P.D. GmbH.

In the event of a warranty claim for defects, which appear within the warranty period, customer shall deliver the product along with proof of purchase to the original place of purchase, shipping prepaid. Repair, replacement or refund of the purchase price of the defective product will be at the sole option of the manufacturer. All transportation risks and costs in connection with warranty service are the responsibility of the customer.

E.E.P.D. GmbH | Gewerbering 3 | 85258 Weichs

Copyright ©2020|2021 E.E.P.D. GmbH.  
All rights reserved.  
10/2021 Revision 1.7

THIS WARRANTY IS IN LIEU OF ALL OTHER WARRANTIES, EXPRESS OR IMPLIED, INCLUDING WITHOUT LIMITATION, IMPLIED WARRANTIES OF MERCHANTABILITY AND FITNESS FOR A PARTICULAR PURPOSE, TO ANY CUSTOMER, CONSUMER, END USER, PURCHASER, OR OTHERWISE. IN NO EVENT SHALL MANUFACTURER BE LIABLE FOR LOSS OF PROFITS, INDIRECT, SPECIAL, INCIDENTAL, OR CONSEQUENTIAL DAMAGES ARISING OUT OF ANY BREACH OF CONTRACT OR WARRANTY, NEGLIGENCE, STRICT LIABILITY OR OTHERWISE.

The remedies for defects in this product are limited to those set forth above. If this limitation of remedies is held by any court to be void or unenforceable, or if no warranty is made, manufacturers liability shall in no event exceed the purchase price of the product giving rise to the claim, regardless of whether such claim is brought in breach of contract or warranty, negligence, strict liability or otherwise.

## Reshipment

If you return the product to E.E.P.D. GmbH please remove all connections and peripheral equipment.

Protect the unit through a suitable packaging, preferably use the original packaging.

## Packaging

The product is in a protective package to avoid damage during transport.  
This protective package should be environmentally friendly recycled after use.

## Disposal of Device



At the end of the lifetime please dispose and/or recycle the components of the device accordingly.

## Technical Support

For technical information about hardware and software please contact:  
[support@eepd.de](mailto:support@eepd.de)

## Table of Contents

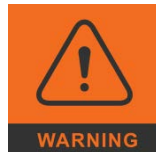
<b>General Notes</b> .....	<b>1</b>
<b>Used Symbols</b> .....	<b>6</b>
<b>1 Product Description</b> .....	<b>7</b>
1.1 Feature Overview .....	7
1.2 Environmental Specification .....	9
<b>2 System Overview</b> .....	<b>10</b>
<b>3 Assembly</b> .....	<b>11</b>
<b>4 Feature Details</b> .....	<b>18</b>
4.1 Mini-DP Connectors .....	19
4.2 Dual-USB 3.1 Gen2 Port .....	20
4.3 Gigabit Ethernet Dual-Port .....	20
4.4 Power Connector .....	21
4.5 DDR4 RAM SODIMM Sockets .....	22
4.6 Battery Connector .....	23
4.7 Audio Connector .....	24
4.8 M.2 Sockets .....	25
4.9 Rear USB-C Port .....	26
4.10 Audio Jack .....	26
4.11 Jumpersetting for eDP Backlight – OEM/ODM only .....	27
4.12 SATA Data Connector .....	28
4.13 SATA Power Connector .....	28
4.14 eDP Connector – OEM/ODM only .....	29

4.15 Power Button, Power and SATA LEDs .....	30
4.16 Reset Connector .....	30
4.17 Power Button Connector .....	31
4.18 FAN Connectors .....	32
4.19 RS232/485 Connectors .....	33
4.20 Feature Connector .....	34
4.21 USB Internal Connector .....	35
<b>5 BIOS</b> .....	<b>36</b>
5.1 Entering Setup .....	36
5.2 Main Menu .....	37
5.3 Advanced Menu .....	40
5.4 Security Menu .....	70
5.5 Power Menu .....	72
5.6 Boot Menu .....	74
5.7 AMD PBS Menu .....	80
5.8 AMD CBS Menu .....	84
5.9 Exit Menu .....	102
<b>Revision History</b> .....	<b>104</b>
<b>Index of Figures</b> .....	<b>105</b>
<b>Index of Tables</b> .....	<b>107</b>
<b>Terminology</b> .....	<b>108</b>
<b>Classified Index</b> .....	<b>109</b>

## Used Symbols



The red danger sign warns you when a wrong or missing action dramatically endangers your life or health. The used components as well as the peripheral components could be destroyed.



The orange warning sign warns you when a wrong or missing action could seriously harm your health or destroy the used components.



The yellow caution sign warns you when a wrong or missing action could damage the component.



The yellow ESD sign draws your attention that static sensitive parts of the component could be destroyed. Unpack shielded components only with ESD protections like an ESD wrist strap.



The information sign gives you more information and advice for optimal use of this product. For example, it helps you to purchase necessary or optional accessories.

## Product Description

In the first chapter you will get a glance of all the integrated features. For further information and a brief description of all possible changes and extensions please refer to the corresponding chapter.

### 1.1 Feature Overview

#### Power Supply

Designed for min. 10.8 V to max. 26.4 V (DC) single power supply, 10 A fused  
EMI filtering  
2-pin barrel connector for external DC Power and Ground

#### Processor Support

AMD V2000 processor series

V2516 / 6C / 12T / 2.1 GHz – 3.95 GHz / 10 – 25 W  
V2718 / 8C / 16T / 1.7 GHz – 4.15 GHz / 10 – 25 W

#### Ethernet Controller

2 Intel® i225 2.5Gbit Ethernet PCI Express® controllers with IEEE1588.

#### RAM Support

Max. 32 GB dual channel DDR4 SODIMM, up to 3200 MT/s

#### Display

2 Mini-DP++ connectors, up to 4096 x 2160@ 60 Hz



## USB Support

7 USB ports from the SoC:

- 1 Dual-USB 3.1 Gen2 (10 Gb/s), Type A at the front side, support for USB 2.0 and 3.1, max. 900 mA per port
- 1 Single-USB 3.1 Gen2 (10 Gb/s), Type C at the rear side, support for USB 2.0 and 3.1, max. 1.5 A
- 1 USB 2.0 at the M.2 Key B Mini card socket
- 1 USB 2.0 at the M.2 Key E Mini card socket
- 2 internal USB connectors, support for USB 2.0

## Storage Support

- 1 M.2 Mini card socket Key M, 22 mm x 42 mm (for SSD only), SATA or PCIe-x4
- 2 standard SATA III (6Gb/s) upright connector + 2 SATA Power on Molex connector

## Expansion

- 2 M.2 Mini card sockets:
  - 1 Key E, 22 mm x 30 mm, PCIe-x1 and USB2
  - 1 Key B, 30/22 mm x 42 mm / onboard SIM card socket, PCIe-x1 and USB2

## Serial Ports

- 2 RS-232/485 (FDX|HDX Windows 10 only) port (8 wires) on internal Molex connector

## Audio

- MIC IN, stereo HP OUT on 3.5 mm headphone Jack.
- Stereo Line IN, stereo Line OUT on internal Molex connector.

## OS Support

- Microsoft® Windows® 11
- Microsoft® Windows® 10
- Microsoft® Windows® 10 IoT Enterprise
- Linux Ubuntu 20.04 LTS

## Extended Features

Onboard  $\mu$ -Controller-IC for:

- Input voltage level detection
- Power-up sequencing and timing
- System reset management
- Temperature monitoring and FAN control
- Watchdog
- Power button input
- Reset button input
- Feature connector (GPIOs / Status LED)
- Power LED onboard
- Status LED onboard
- RTC battery connector

## 1.2 Environmental Specification

### Max. Operating Temperature

0 °C to +60 °C ambient, when adequate heatsink/cooling is provided.



Other operating temperature ranges upon request.

### Max. Storage Temperature

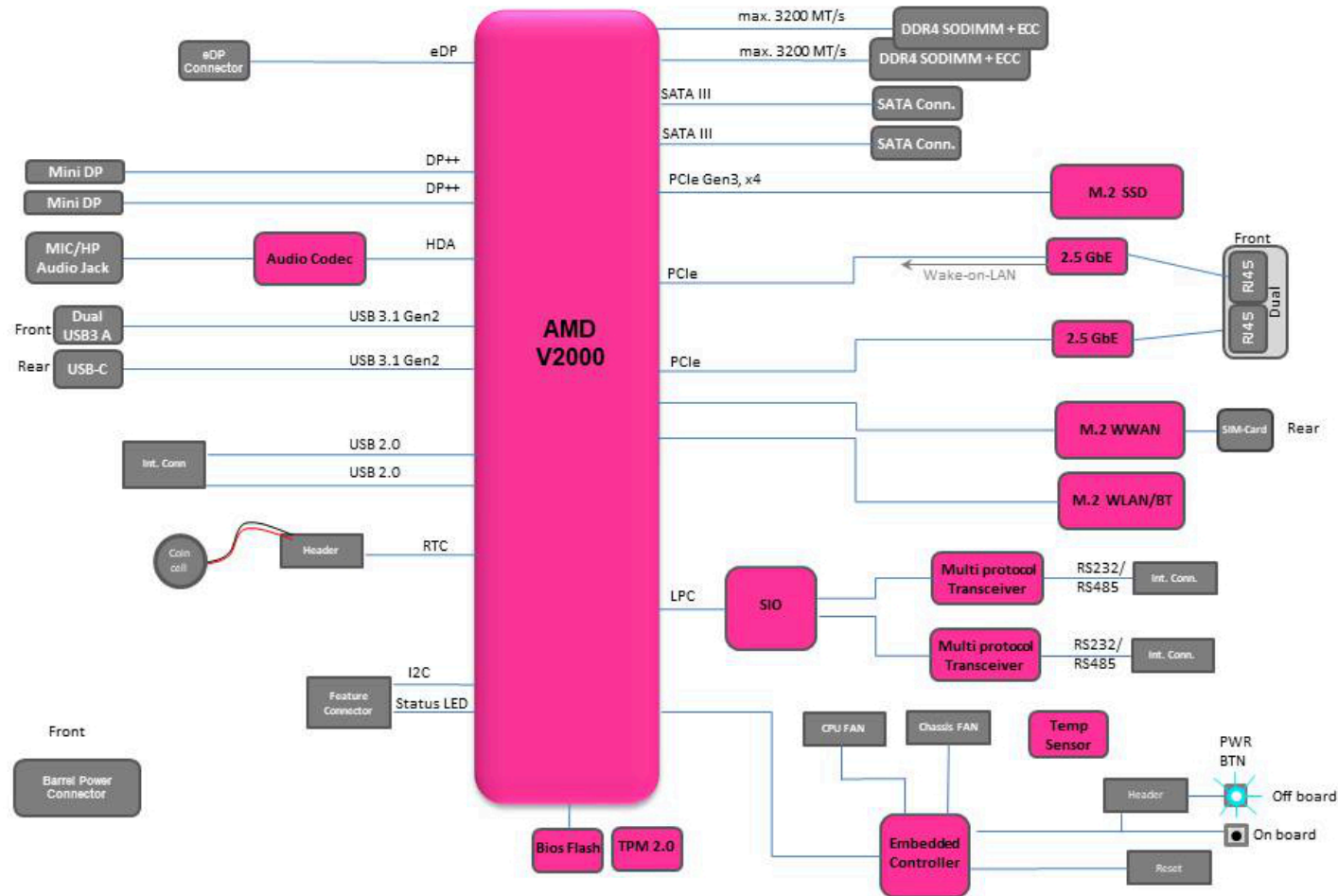
-40 °C to +85 °C

### Max. rel. Humidity for all versions

95 % @ 40 °C non-condensing

## System Overview

This chapter describes the main hardware components of the NUCEX board.



F.F.P.D. GmbH | Gewerhering 3 | 85258 Weichs  
Fig. 1: System Overview

## Assembly

The board must be mounted in a stable case. The mechanical mounting points according to chapter 3.1 must be used.

The available sockets and connector for system build-up are specified in chapter 4.

E.E.P.D. recommends M3 Torx screws with a screw locking coating and a **maximum tightening torque of 0.5 Nm**.

Top View

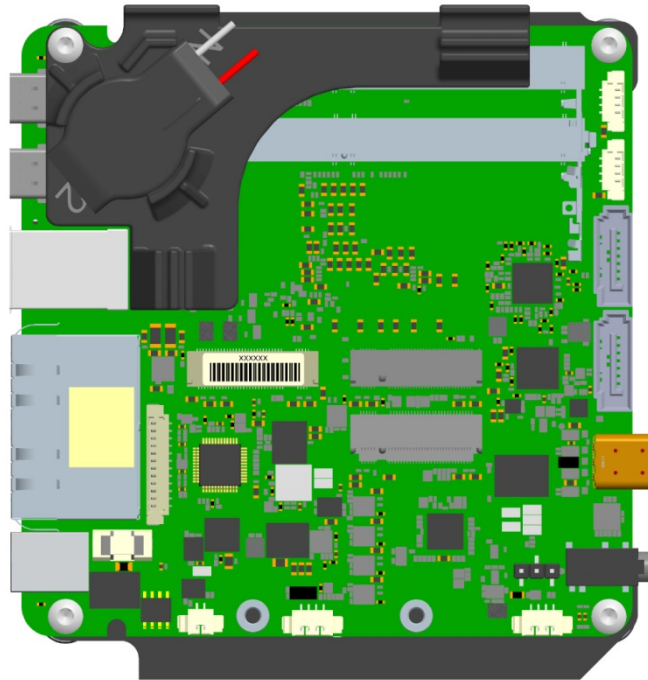


Fig. 2: Top View

Bottom View

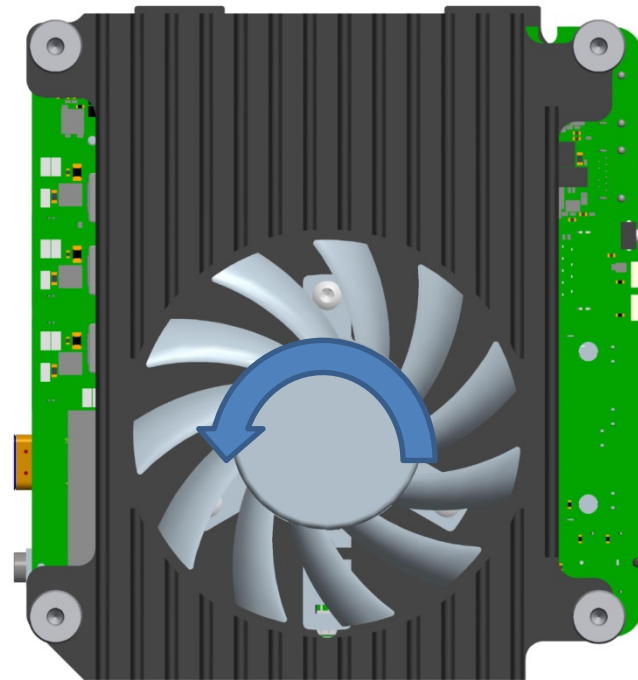


Fig. 3: Bottom View

Front View



Fig. 4: Front View

Rear View

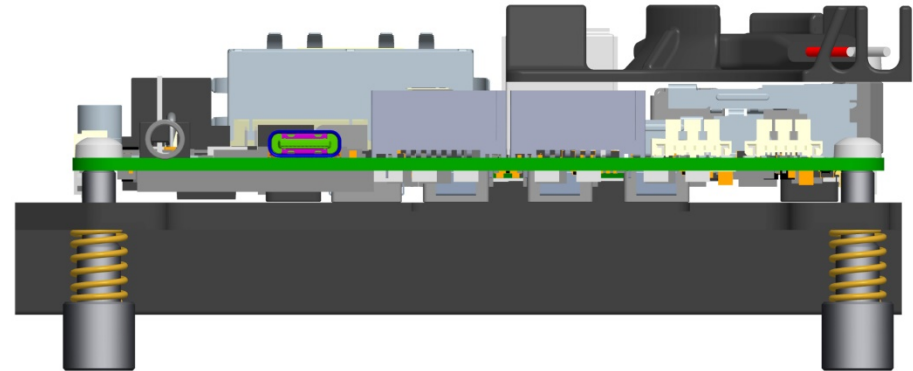


Fig. 6: Rear View

Assembly

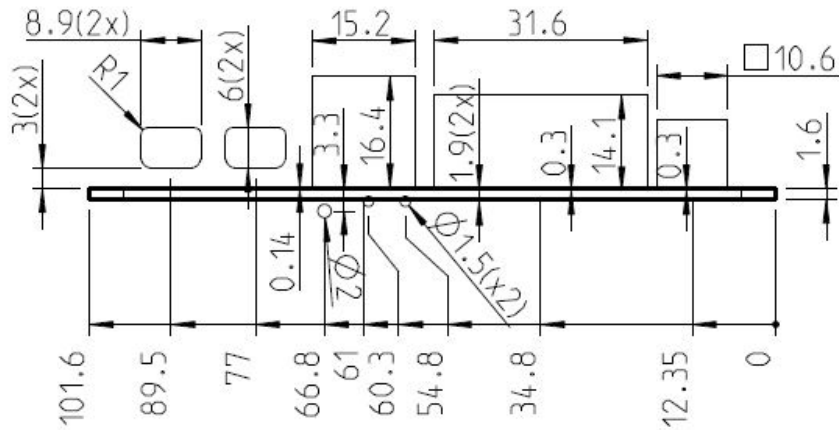


Fig. 5: Recommended cutouts front panel

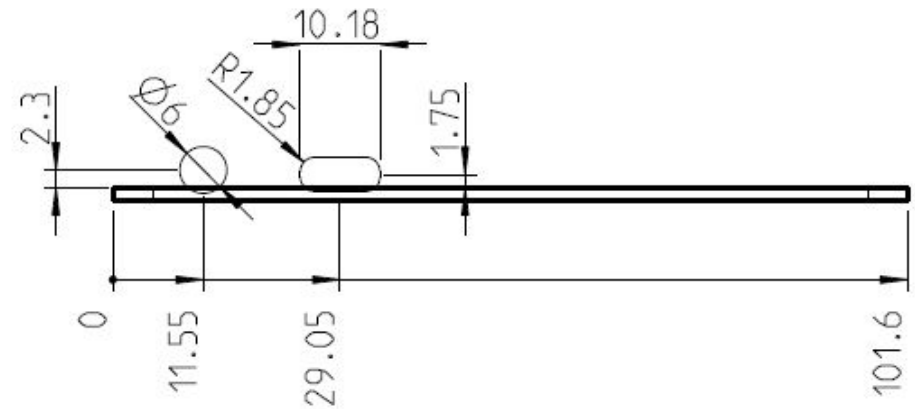


Fig. 7: Recommended cutouts rear panel

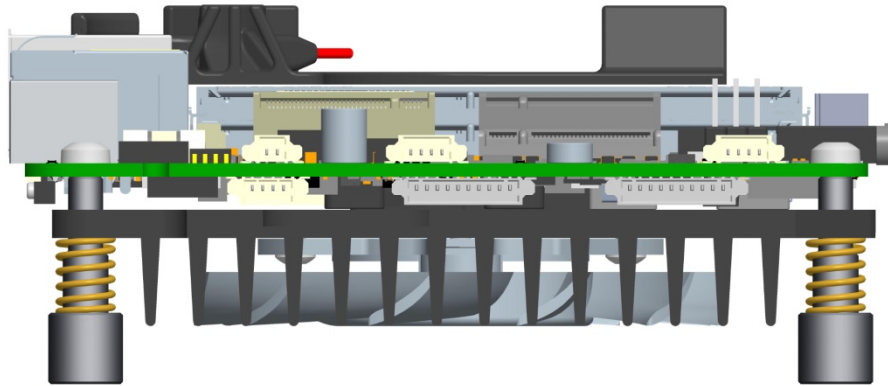
**Side View**

Fig. 8: Side View

## Mechanical Mounting

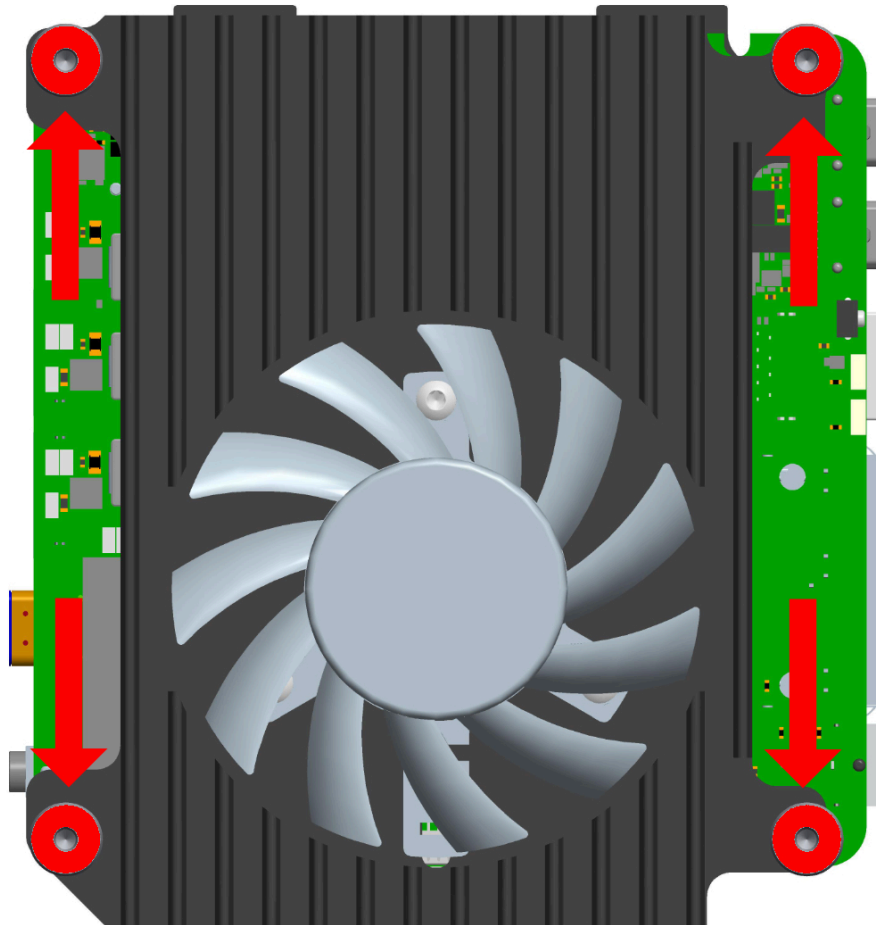


Fig. 9: Mechanical Mounting



Please use the 4 prepared mounting points (red outline) to fasten the base board in order to prevent short circuits. Use 15.24 mm (0.6 inches) distance bolts for a stable mounting of the board.



Do not disassemble the cooling solution, this will void the warranty. The illustration shows an example of a variant with active cooling.



Dimensions of the board

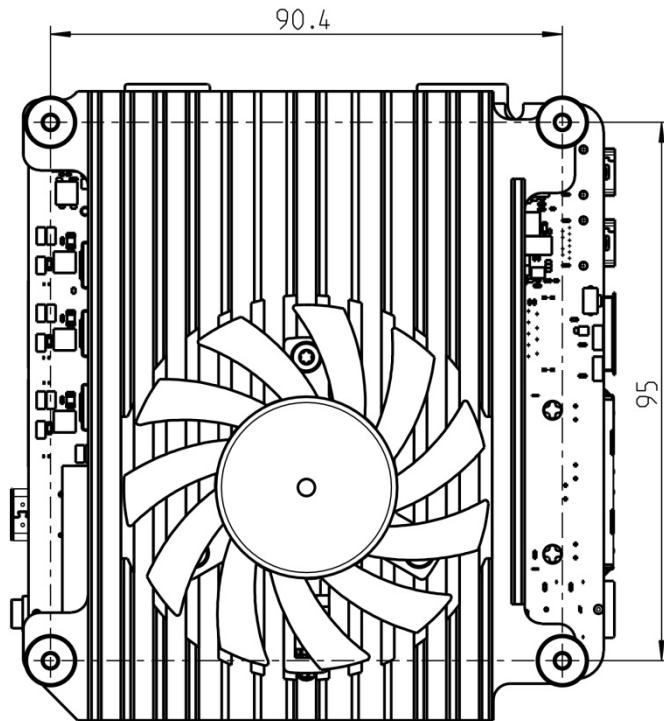


Fig. 10: Dimensions bottom side

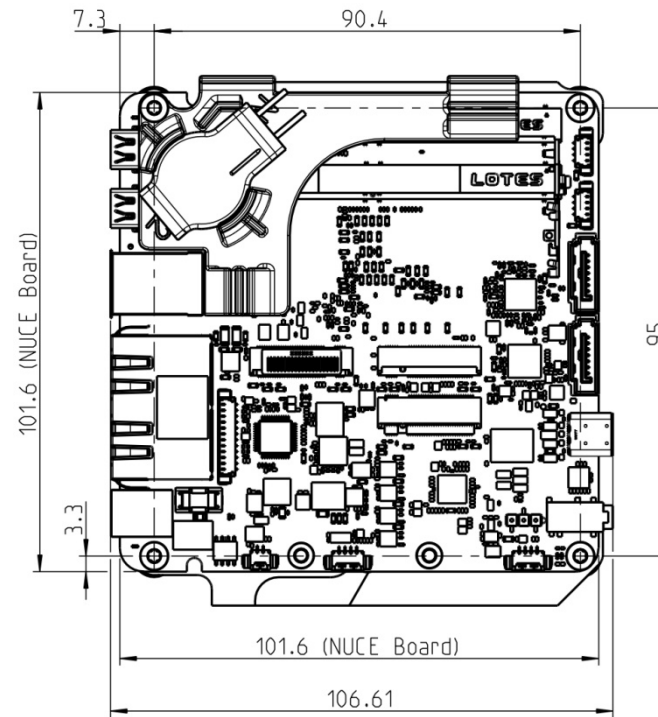


Fig. 11: Dimensions top side

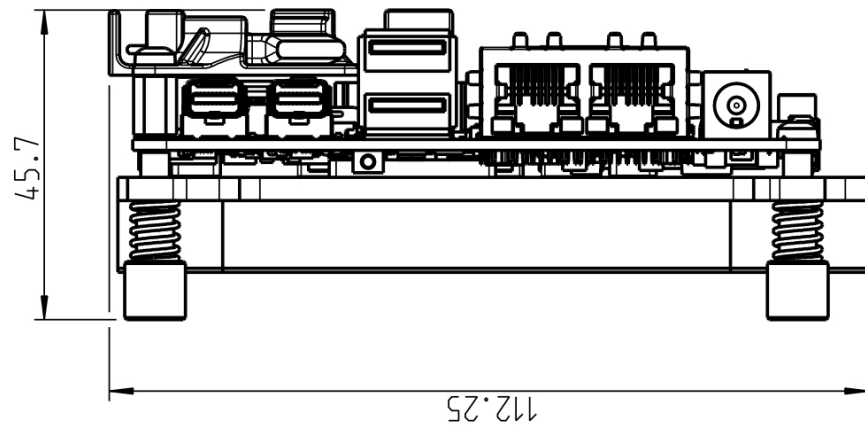


Fig. 12: Dimensions front side

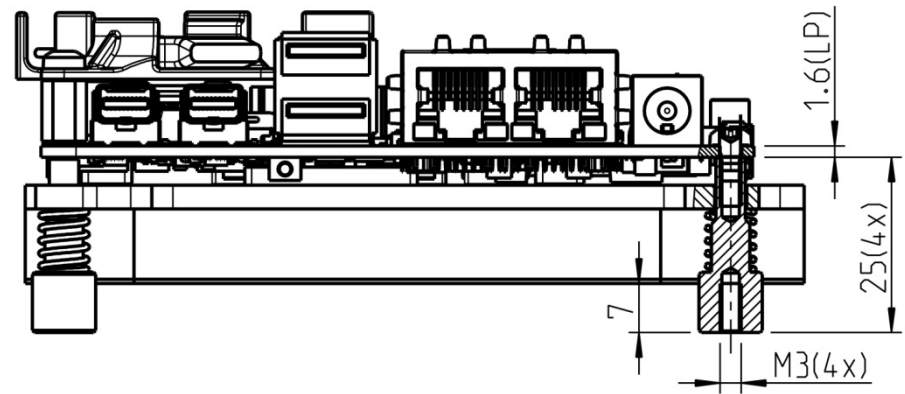


Fig. 14: Dimensions threaded bolts

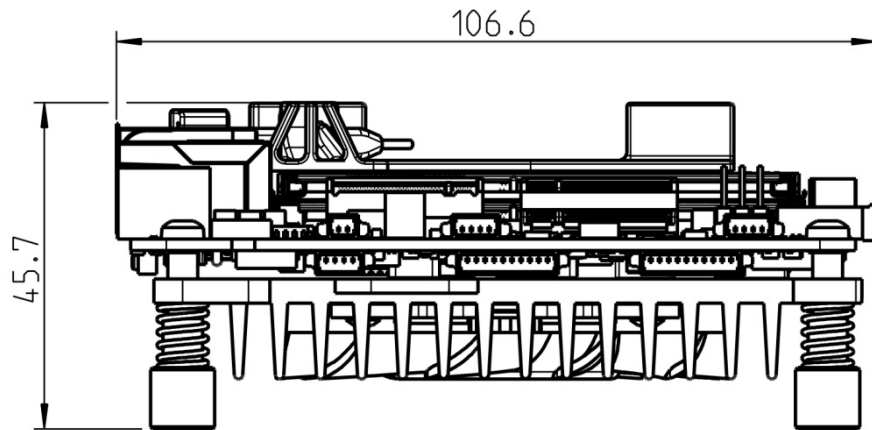


Fig. 13: Dimensions side

## Feature Details

The following schedule contains all the necessary information to connect the board to your peripheral equipment.

On the left side of the page, you will see the position on the board (red mark) and on the right side a magnified image of the explained item.

The explanation provides general information, electrical specifications and a pin assignment table.

All voltages are DC:	
VCC	5 V +/-5%
P3V3	3.3 V +/-5%
P12V_DISPLAY	12 V +/-5%

## 4.1 Mini-DP Connectors

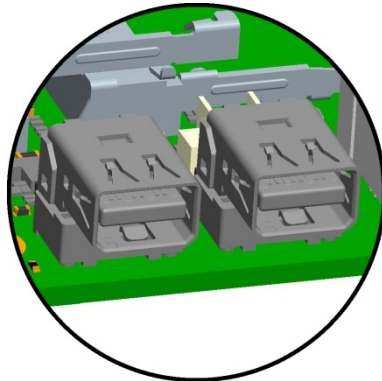
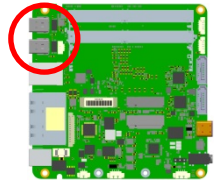


Fig. 15: Mini-DP Connector Detail

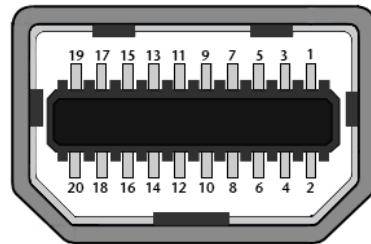


Fig. 16: Mini-DP Connector Schematic



Important note:

There are two kinds of DisplayPort cables:  
Cables for **direct connection** to a MiniDP monitor with **Pin 20** on both ends of the cable **NOT connected**.

Cables for use with **dongles** (e.g. MiniDP to DP, MiniDP to HDMI) with **Pin 20** on both ends of the cable **connected**.

Possible effects if wrong cable is used:

System might not start up properly.

Dongle does not work properly (black display).

## 4.2 Dual-USB 3.1 Gen2 Port



USB 3.1 Gen2 type ports providing max. 900 mA per port.

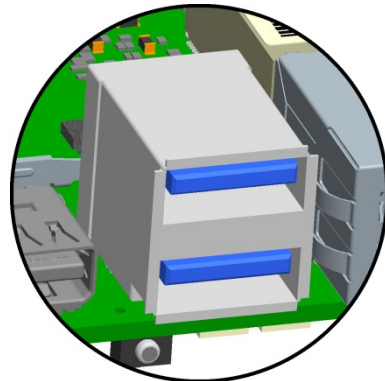
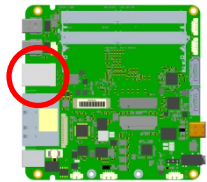


Fig. 17: Dual-USB 3.1 Port Detail

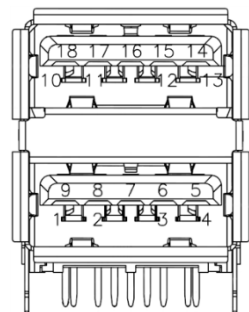


Fig. 18: Dual-USB 3.1 Port Schematic

## 4.3 Gigabit Ethernet Dual-Port

The Dual-Ethernet socket uses the Intel® 2.5Gigabit Ethernet Controller Intel® i225. ETH1 supports wake-on-LAN.

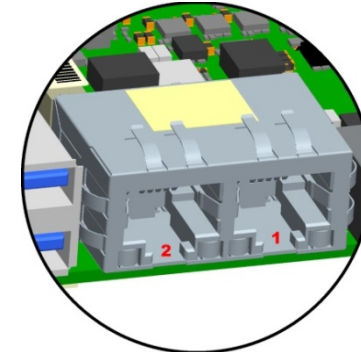
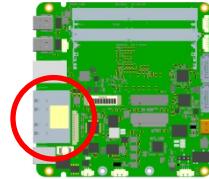


Fig. 19: Ethernet Dual-Port Detail

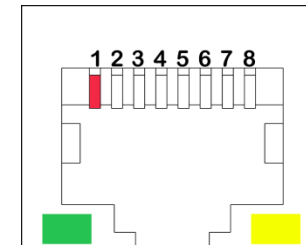


Fig. 20: Ethernet Port Schematic

### Yellow LED

Speed-LED is on during 2.5 or 1 Gbit transmission and switched off during 10/100 Mbit transmission.

### Green LED

Link-/Activity-LED is permanently on to indicate an active connection on the Ethernet port. LED flashes during communication with the Ethernet network.

#### 4.4 Power Connector



For a stable operation:  
 Please ensure a system power supply of min. 60 W.  
 E.E.P.D. recommends a system power supply of 90 W.  
 Power source must be capable to respond to fast load changes!  
 Supply voltage (PVIN) min. 10.8 V / max. 26.4 V (DC)

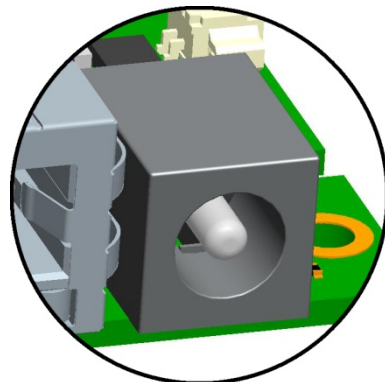
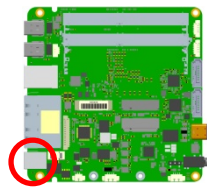


Fig. 21: Power Connector Detail

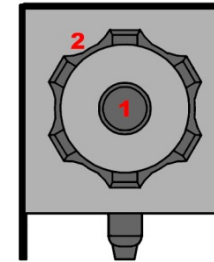


Fig. 22: Power Connector Schematic



Counterpart – plug:  
 CUI Devices Power Plug ID 2.5mm, AD 5.5mm  
 Ordering number: PP3-002B

Pin	Signal
1	PVIN
2	GND

Tab. 1: Power Connector

## 4.5 DDR4 SODIMM Sockets

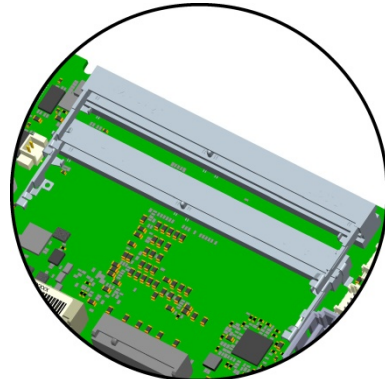
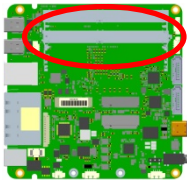


Fig. 23: DDR4 SODIMM Socket Detail



Use only 1.2 V DDR4 SODIMM modules compliant with the DDR4 Standard.

### Assembly:

First slide RAM module into the RAM socket.

Then press the module in direction to the board till you hear it snap.

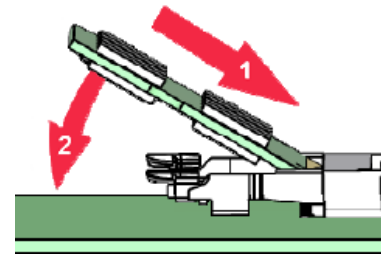


Fig. 24: RAM Assembly

### Disassembly:

First press both clamps outwards.

Then the RAM module will set upright automatically.

Remove the card from the socket.

### 4.6 Battery Connector

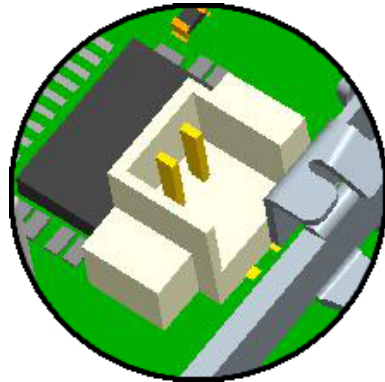
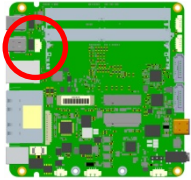


Fig. 25: Molex Battery Connector Detail

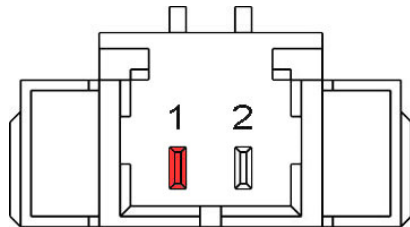


Fig. 26: Molex Battery Connector Schematic



Counterpart – plug:  
MOLEX Pico Blade 0510210200

Pin	Signal
1	BATT
2	GND

Tab. 2: Battery Connector



### 4.7 Audio Connector

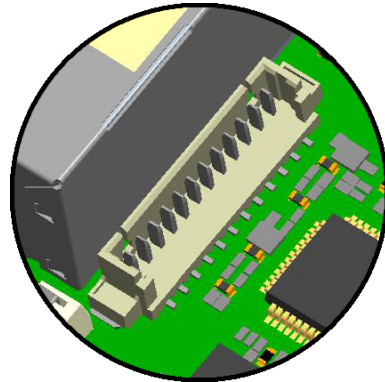
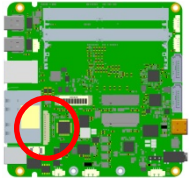


Fig. 27: Molex Audio Connector Detail

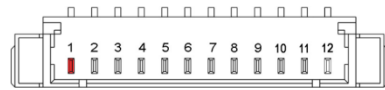


Fig. 28: Molex Audio Connector Schematic



Counterpart – plug:  
MOLEX Pico Blade 0510211200

Pin	Signal
1	JD_LINE_IN
2	LINE_IN_L
3	LINE_IN_R
4	GND_AUDIO
5	N.C.
6	GND_AUDIO
7	JD_LINE_OUT
8	LINE_OUT_L
9	LINE_OUT_R
10	GND_AUDIO
11	N.C.
12	N.C.

Tab. 3: Audio Connector



For optimum audio performance:  
Please ensure to use cables provided by E.E.P.D.

## 4.8 M.2 Sockets

**M.2 Socket Key M, 22mm x 42mm, SATA or PCIe-x4**

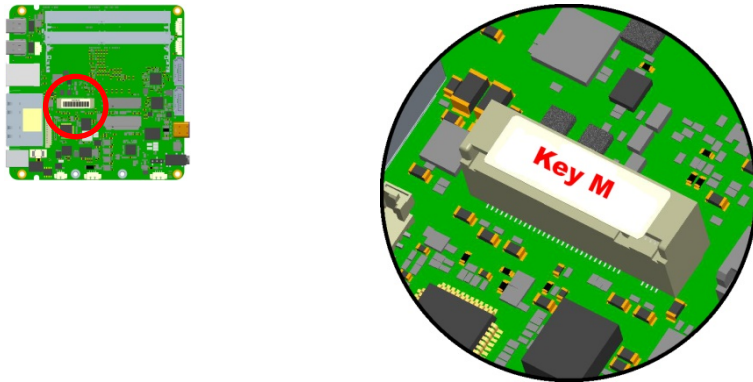


Fig. 29: M.2 Key M Connector Detail

**M.2 Socket Key E, 22mm x 30mm, PCIe-x1 and USB2**

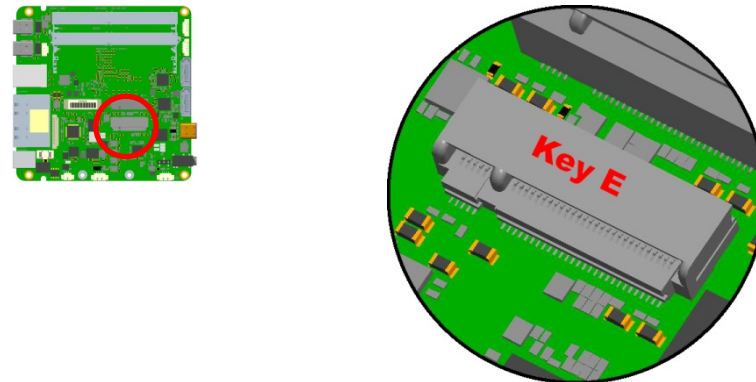


Fig. 30: M.2 Key E Connector Detail

**M.2 Socket Key B, 30mm x 42mm, PCIe-x1 and USB2**

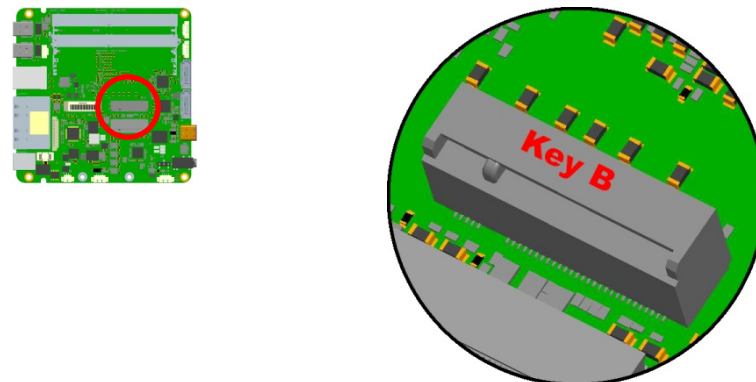


Fig. 31: M.2 Key B Connector Detail

#### 4.9 Rear USB-C Port



Support for USB 2.0 and USB 3.1 Gen2 (10 Gb/s).  
Port provides max. 1.5A

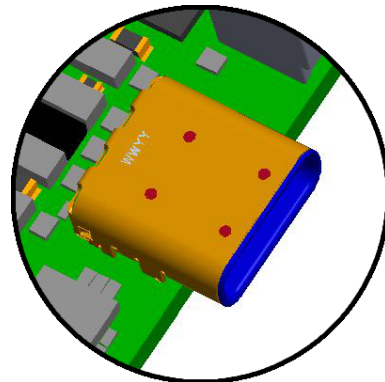
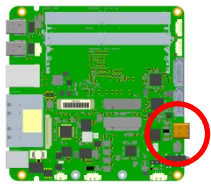


Fig. 32: USB-C Port Detail

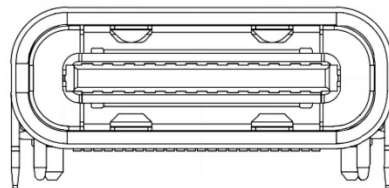


Fig. 33: USB-C Port Schematic

#### 4.10 Audio Jack

3.5 mm Audio Jack provides mono microphone IN and stereo headphone OUT.

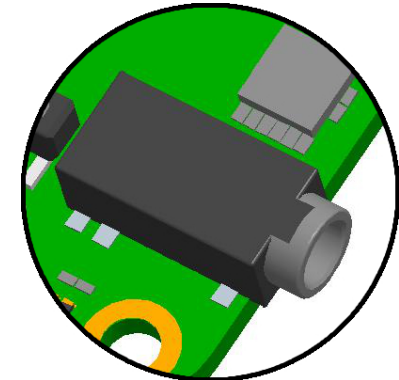
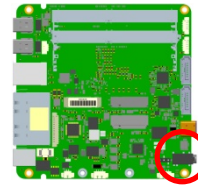


Fig. 34: Audio Jack Detail

### 4.11 Jumpersetting for eDP Backlight – OEM/ODM only

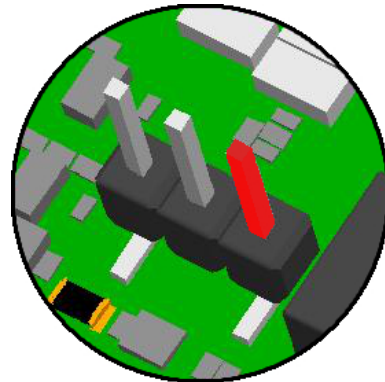
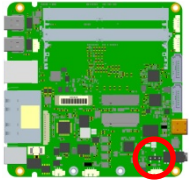


Fig. 35: STL3X1 Detail

Pin	Signal
1	PVIN -> 10.8V – 26.4V*
2	VDD_BKL
3	VCC_A -> 5V +/- 5%

Tab. 4: STL3X1

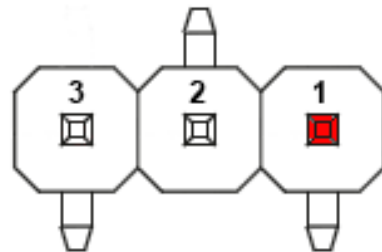


Fig. 36: STL3X1 Schematic

\*depends on power in voltage

### 4.12 SATA Data Connector

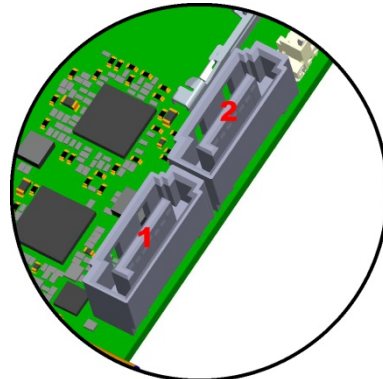
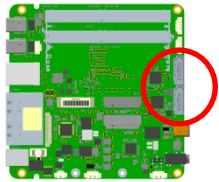


Fig. 37: SATA Data Connector Detail

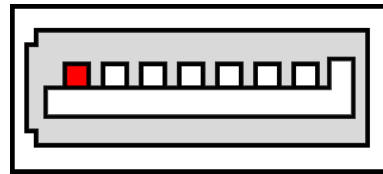


Fig. 38: SATA Data Connector Schematic

### 4.13 SATA Power Connector

Provides 1.5 A.

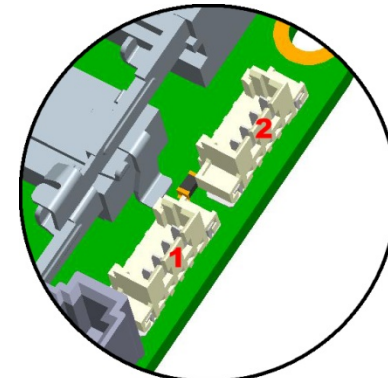
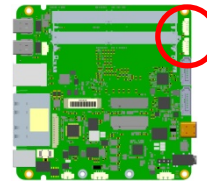


Fig. 39: Molex SATA Power Connector Detail

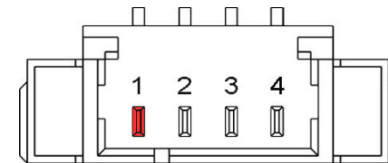


Fig. 40: Molex SATA Power Connector Schematic



Counterpart – plug:  
MOLEX Pico Blade 0510210400

Pin	Signal
1	VCC 5V +/- 5%
2	VCC 5V +/- 5%
3	GND
4	GND

Tab. 5: Molex SATA Power Connector

### 4.14 eDP Connector – OEM/ODM only

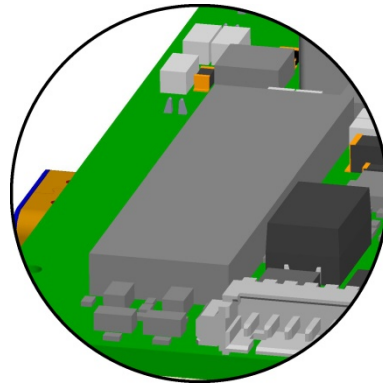
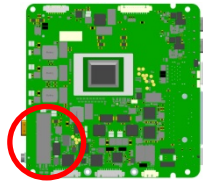


Fig. 41: eDP Connector Detail

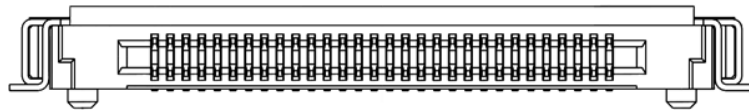


Fig. 42: eDP Connector Schematic



Counterpart – plug:  
e.g. ACES 50204-40

Pin	Signal	Pin	Signal
1	N.C.	23	GND
2	GND	24	GND
3	eDP_TX3_N	25	GND
4	eDP_TX3_P	26	GND
5	GND	27	eDP_HPD
6	eDP_TX2_N	28	GND
7	eDP_TX2_P	29	GND
8	GND	30	GND
9	eDP_TX1_N	31	GND
10	eDP_TX1_P	32	eDP_BKLEN
11	GND	33	eDP_BKLCTL
12	eDP_TX0_N	34	N.C.
13	eDP_TX0_P	35	N.C.
14	GND	36	VDD_BKL* <sup>2</sup>
15	eDP_AUX_P	37	VDD_BKL* <sup>2</sup>
16	eDP_AUX_N	38	VDD_BKL* <sup>2</sup>
17	GND	39	VDD_BKL* <sup>2</sup>
18	VDD_LCD*	40	N.C.
19	VDD_LCD*	41	GND
20	VDD_LCD*	42	GND
21	VDD_LCD*	43	GND
22	N.C.	44	GND

Tab. 6: eDP Connector

\* VDD\_LCD = 10,4V +/-5% (other on request)

\*<sup>2</sup> VDD\_BKL = 5V +/- 5% or PVIN, depends on jumper setting (4.11)

### 4.15 Power Button, Power and SATA LEDs

Press power button once to start up.

Press power button to shut down into S3/S4 (Standby/Hibernate; depending on OS setting).

Hold power button (> 4 sec.) to shut down into S5 (OFF).

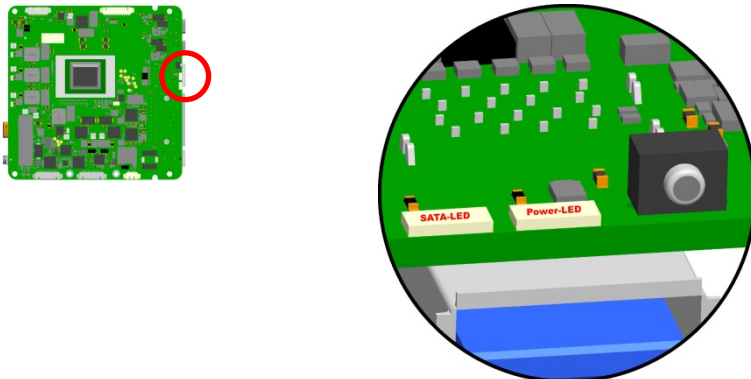


Fig. 43: Power Button/Power and SATA LEDs Detail

### 4.16 Reset Connector

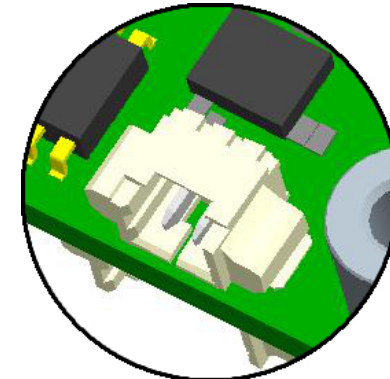
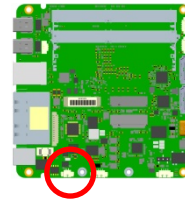


Fig. 44: Molex Reset Connector Detail

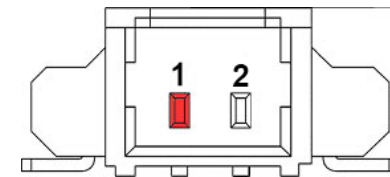


Fig. 45: Molex Reset Connector Schematic



Counterpart – plug:  
MOLEX Pico Blade 0510210200

Pin	Signal
1	RESET_IN
2	GND

Tab. 7: Molex Reset Connector



### 4.17 Power Button Connector

Press power button once to start up.

Press power button to shut down into S3/S4 (Standby/Hibernate; depending on OS setting).

Hold power button (> 4 sec.) to shut down into S5 (OFF).

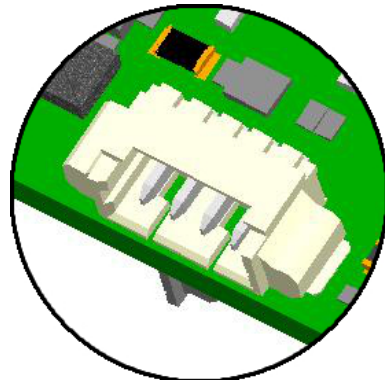
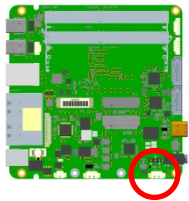


Fig. 46: Molex Power Button Connector Detail

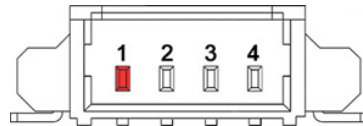


Fig. 47: Molex Power Button Connector Schematic



Counterpart – plug:  
MOLEX Pico Blade 0510210400

Power cable, 80 mm:  
Ordering number W-NUPWON3

Pin	Signal
1	PWR_LED_ANODE 3.3V +/- 5% with 100 Ohm series resistor
2	PWR_LED_CATHODE
3	GND
4	POWERBUTTON

Tab. 8: Molex Power Button Connector



## 4.18 FAN Connectors

### SoC FAN Connector

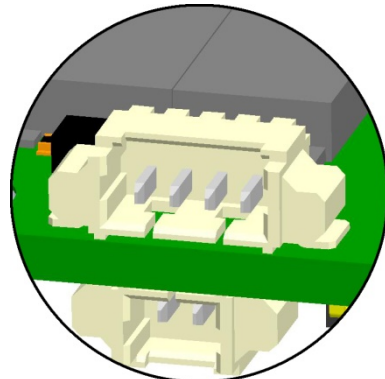
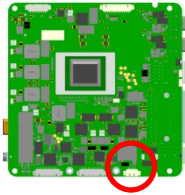


Fig. 48: Molex SoC FAN Connector Detail

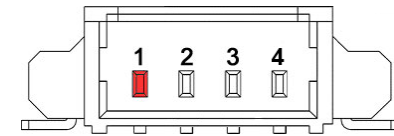


Fig. 50: Molex FAN Connector Schematic



Counterpart – plug:  
MOLEX Pico Blade 0510210400

### SSD FAN Connector

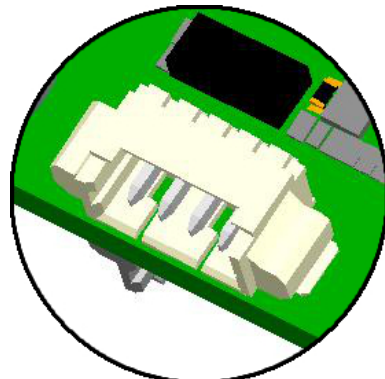
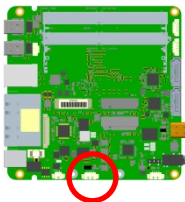


Fig. 49: Molex SSD FAN Connector Detail

Pin	Signal
1	GND
2	VDD_FAN *
3	FAN_TACHO
4	FAN_PWM

Tab. 9: Molex FAN Connectors

\*Voltage depends on board variant (applies to SoC and SSD FAN connector):

NUCEA-B, NUCEF-G, NUCEO = 5V +/- 5%

### 4.19 RS232/485 Connectors

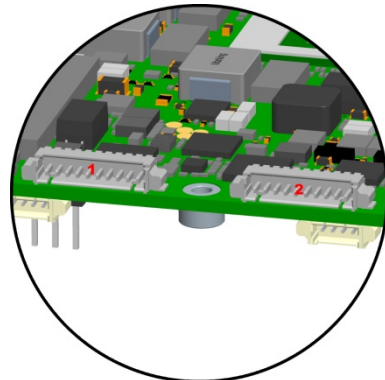
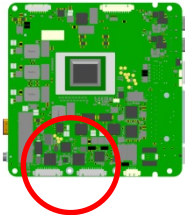


Fig. 51: Molex RS232/485 Connector Detail

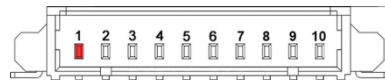


Fig. 52: Molex RS232/485 Connector Schematic



Counterpart – plug:  
MOLEX Pico Blade 0510211000

RS232 cable ordering number: W-RS232M1B  
RS485 cable ordering number: W-RSXXXM1A

Pin	Signal
1	DCD_m
2	DSR_m
3	RXD
4	RTS_m
5	TXD
6	CTS_m
7	DTR_m
8	RI_m
9	VCC 5V +/- 5% (not fused)
10	GND

Tab. 10: Molex RS232/485 Connectors

### 4.20 Feature Connector

Status LED and GPIO Connector.

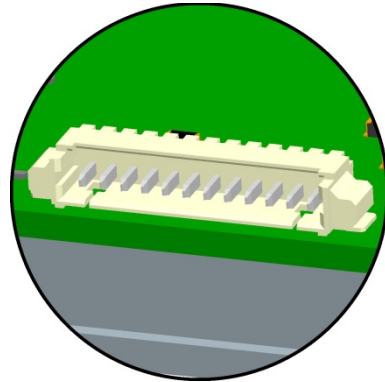
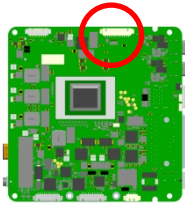


Fig. 53: Molex Feature Connector Detail

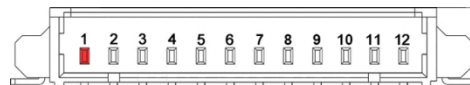


Fig. 54: Molex Feature Connector Schematic



Counterpart – plug:  
MOLEX Pico Blade 0510211200

Pin	Signal
1	3.3V +/- 5%
2	N.C.
3	GPIO0 *
4	GPIO1 *
5	GPIO2 *
6	GPIO3 *
7	GPO4 * <sup>2</sup>
8	GPO5 * <sup>2</sup>
9	GPO6 * <sup>2</sup>
10	STATUS_LED_ANODE 3.3V +/- 5% with 100 Ohm series resistor
11	STATUS_LED_CATHODE
12	GND

Tab. 11: Molex Feature Connector

\* GPIO [0:3]: max. 3.3V

\*<sup>2</sup> GPO [4:6]: max. voltage = PVIN max. -> 26.4V  
series resistor = 0 Ohm

### 4.21 USB Internal Connector

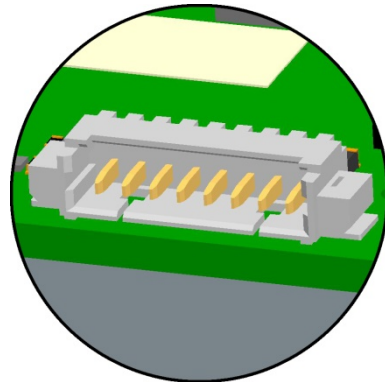
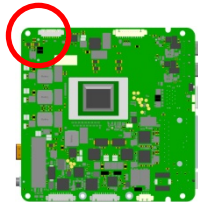


Fig. 55: Molex USB internal Connector Detail

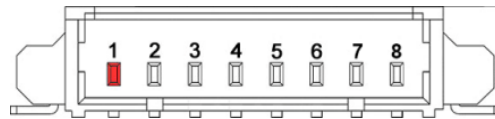


Fig. 56: Molex USB internal Connector Schematic



Counterpart – plug:  
MOLEX Pico Blade 0510210800

Pin	Signal
1	VCC_USB2_6_INT -> 5V +/- 5% fused, 900mA
2	USB2_6_INT_N
3	USB2_6_INT_P
4	GND
5	VCC_USB2_7_INT -> 5V +/- 5% fused, 900mA
6	USB2_7_INT_N
7	USB2_7_INT_P
8	GND

Tab. 12: Molex USB internal Connector

## BIOS

The BIOS ROM has a built-in Setup program that allows users to modify the basic system configurations. This type of information is stored in battery-backed CMOS RAM, so that Setup information is retained when the power is turned off.

The following description shows a snapshot of the BIOS setup. Later BIOS updates may change the content slightly.

### 5.1 Entering Setup

Power on the board and press and hold [ESC] immediately to enter Setup.

## 5.2 Main Menu

Once you enter the Setup Utility, the Main Menu will appear on the screen.



Fig. 57: Main Menu 1

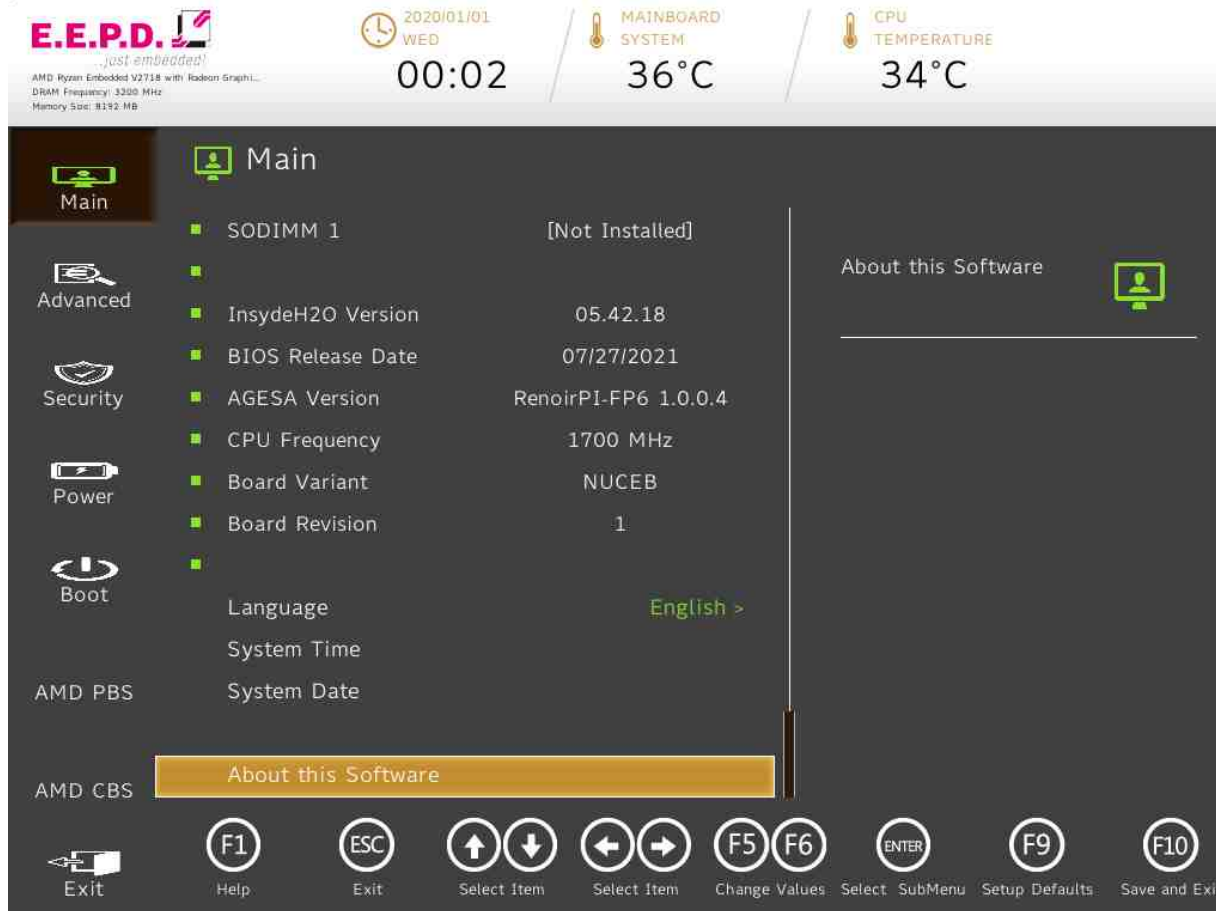


Fig. 58: Main Menu 2

BIOS Settings	Options	Description
Language	<English>*	Select the current default language used by the InsydeH2O.
System Time	No options	This is the help for the hour, minute, second field. Valid range is from 0 to 23, 0 to 59, 0 to 59. INCREASE/REDUCE: +/-.
System Date	No options	This is the help for the month field, day field, year field. Valid range is from 1 to 12, 1 to 31, 2000 to 2099. (Error checking will be done against month/day/year combinations that are not supported.) INCREASE/REDUCE: +/-.
About this Software		

Tab. 13: Main Menu



### 5.3 Advanced Menu

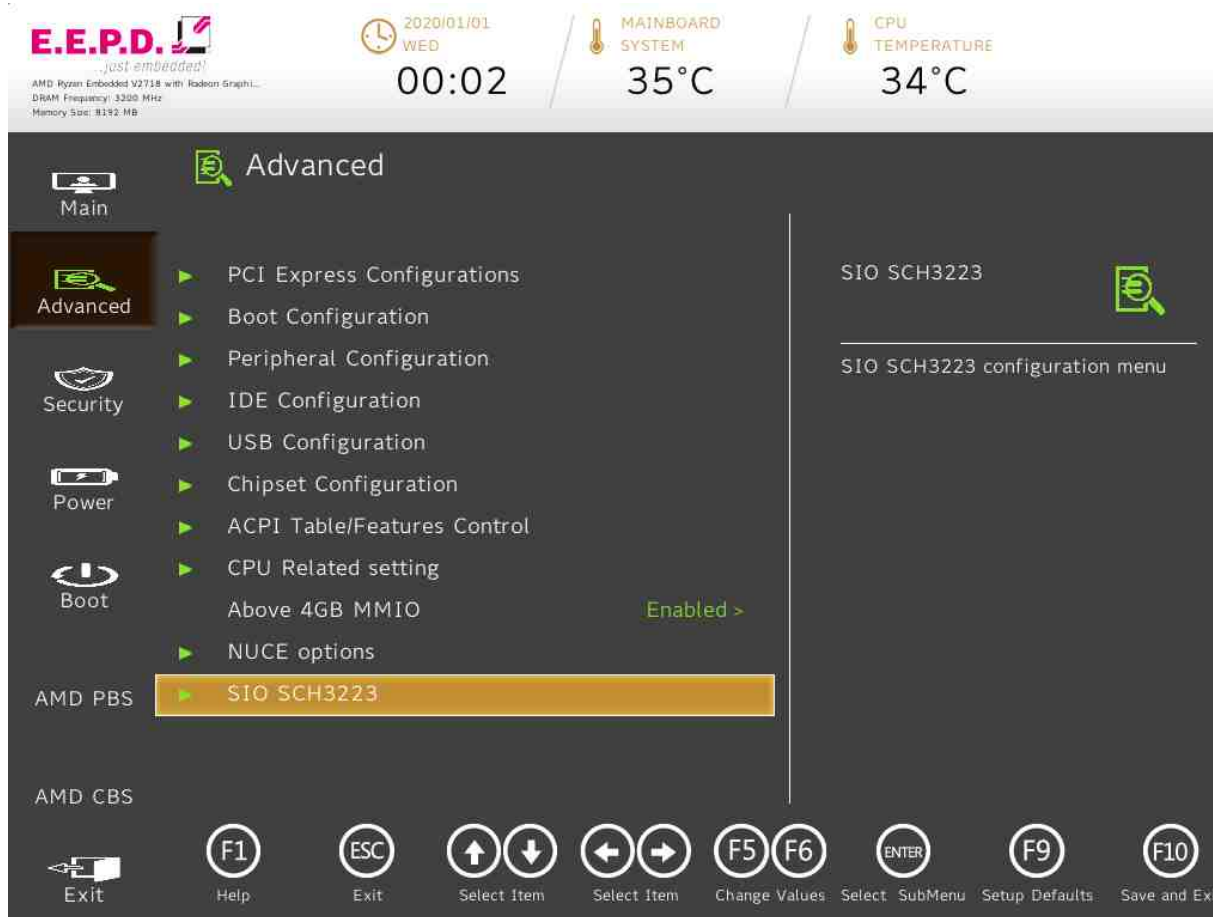


Fig. 59: Advanced Menu

BIOS Settings	Options	Description
PCI Express Configurations	No options	PCI Express Configurations
Boot Configuration	No options	Configures Boot Settings.
Peripheral Configuration	No options	Configures the peripheral devices.
IDE Configuration	No options	Select the IDE controller and hard disk drive type installed in your system
USB Configuration	No options	Configure the USB support
Chipset Configuration	No options	Advanced Chipset Configuration Options.
ACPI Table/Features Control	No options	Configures ACPI Tables/Features setting.
CPU Related setting	No options	CPU Related setting
Above 4GB MMIO	<Disabled> <Enabled>*	Enable/Disable above 4GB MemoryMappedIO BIOS assignment. It's only available with Uefi Boot Mode.
NUCE options	No options	NUCE options: Configure PIC watchdog!
SIO SCH3223	No options	SIO SCH3223 configuration menu

Tab. 14: Advanced Menu

PCI Express Configurations

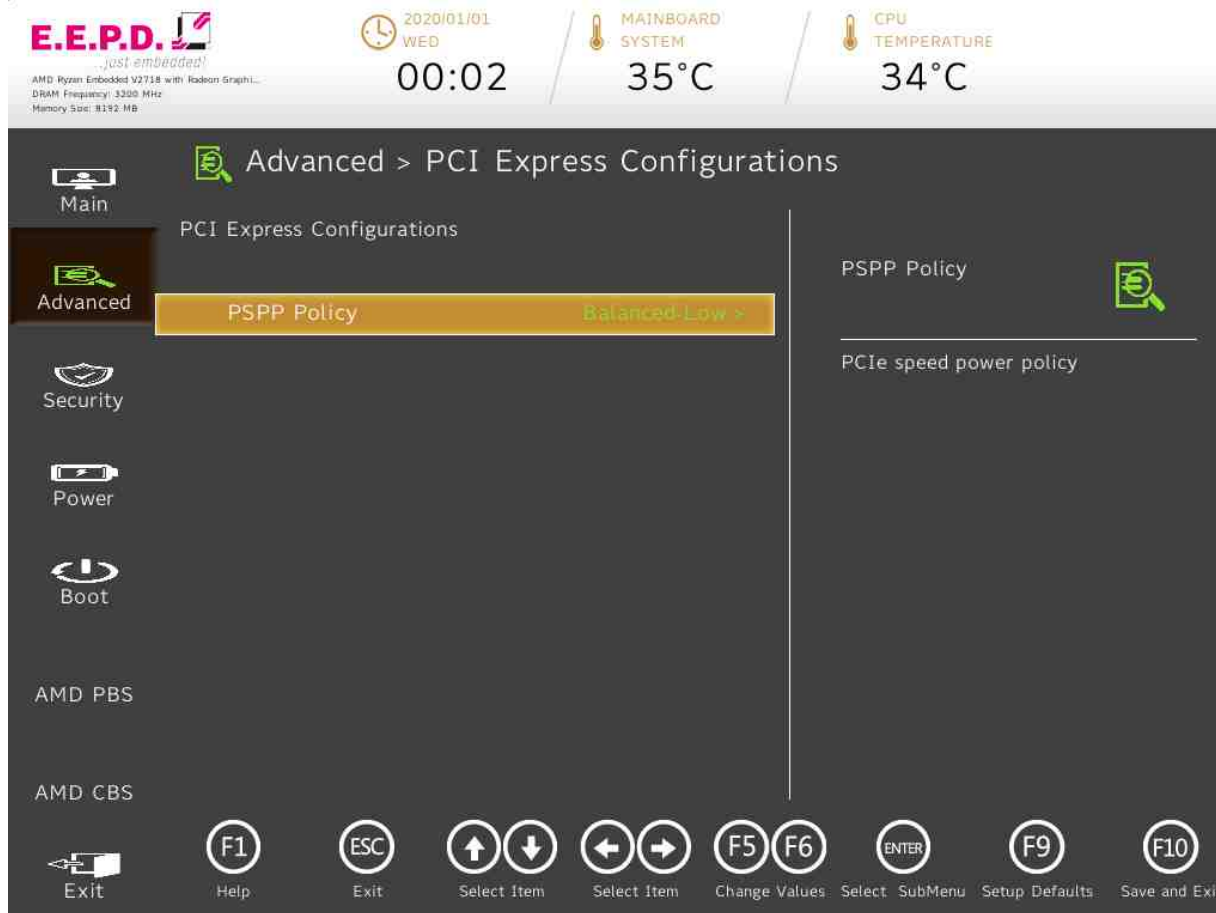


Fig. 60: PCI Express Configurations

BIOS Settings	Options	Description
PSP Policy	<Disabled> <Performance> <Balanced-High> <Balanced-Low>* <Power Saving> <Auto>	PCIe speed power policy

Tab. 15: PCI Express Configuration

**Boot Configuration**

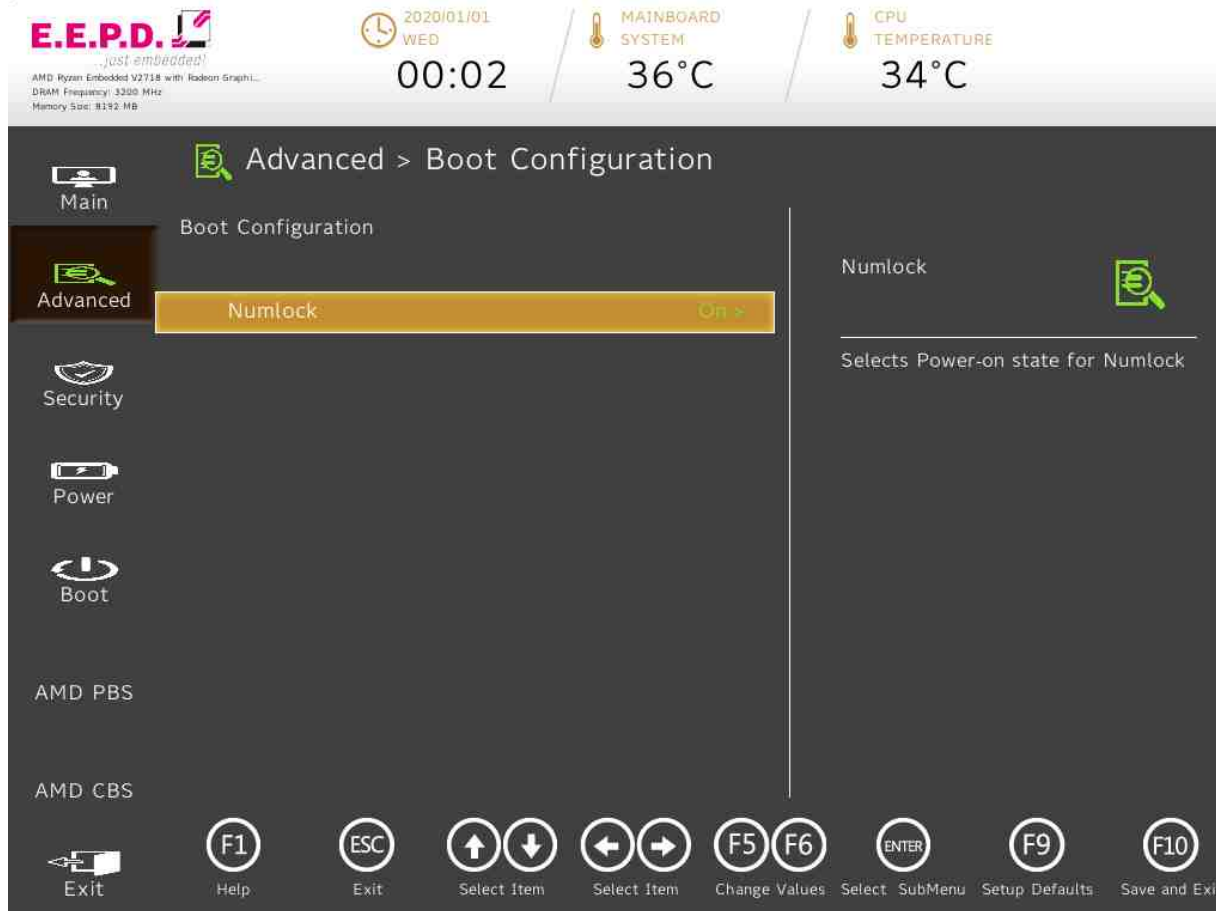


Fig. 61: Boot Configuration

BIOS Settings	Options	Description
Numlock	<Off> <On>*	Selects Power-on state for Numlock

Tab. 16: Boot Configuration

Peripheral Configuration



Fig. 62: Peripheral Configuration

BIOS Settings	Options	Description
Trust Platform Module	<Disabled>* <Enable discrete TPM> <Enable firmware TPM>	Enable/Disable TPM physical presence. Need to reboot when set from disable to enable before selecting TPM Operation.
Erase fTPM NV for factory reset	<Disabled> <Enabled>*	Control if need to erase the TPM NV when fTPM factory reset flag set.

Tab. 17: Peripheral Configuration



IDE Configuration

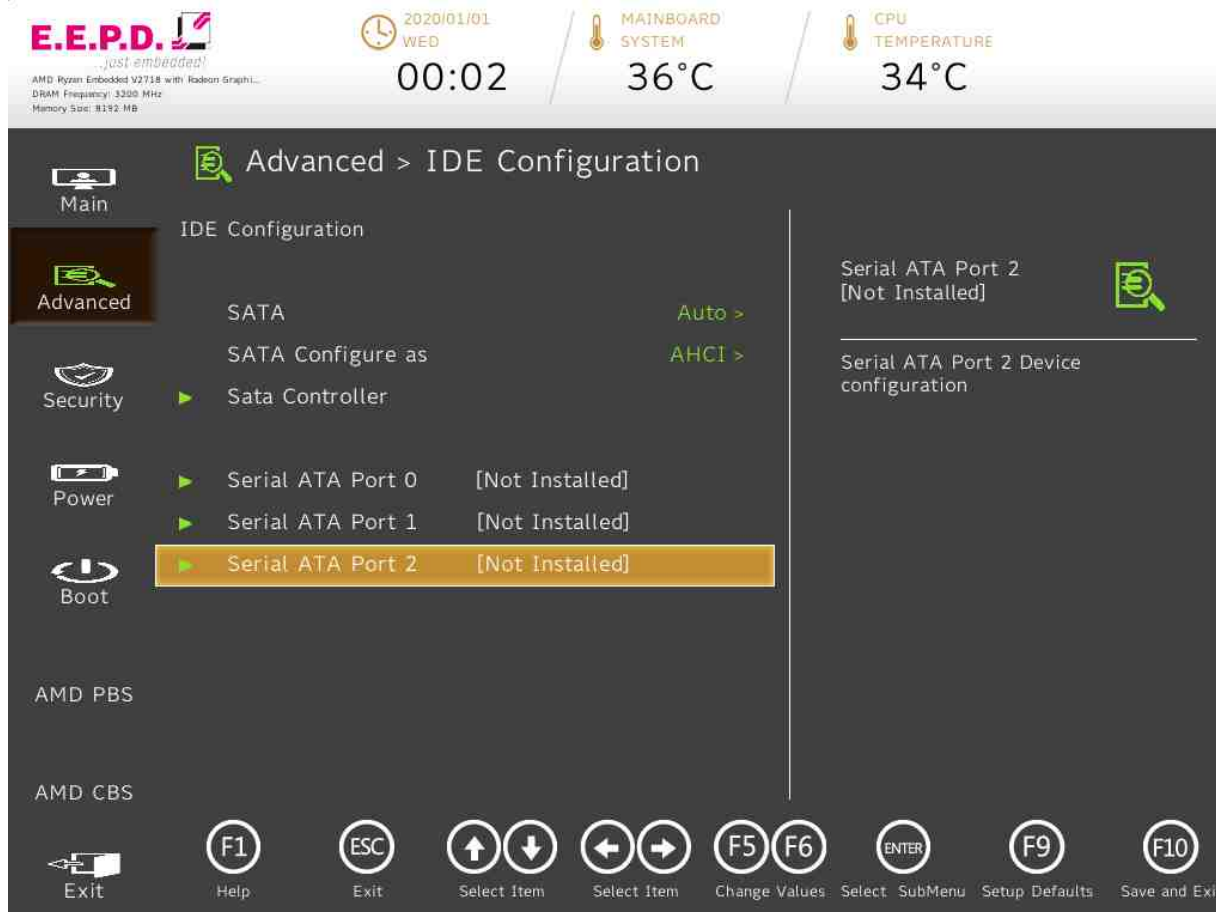


Fig. 63: IDE Configuration

BIOS Settings	Options	Description
SATA	<Disabled> <Auto>*	AUTO: Auto detect the SATA controller. DISABLED: Disable the SATA controller
SATA Configure as	<IDE> <AHCI>*	Set SATA Configure Type
Sata Controller	No options	Enable/Disable SATA Controller
Serial ATA Port 0 [Not Installed]	No options	Serial ATA Port 0 Device configuration
Serial ATA Port 1 [Not Installed]	No options	Serial ATA Port 1 Device configuration
Serial ATA Port 2 [Not Installed]	No options	Serial ATA Port 2 Device configuration

Tab. 18: IDE Configuration

SATA-Controller

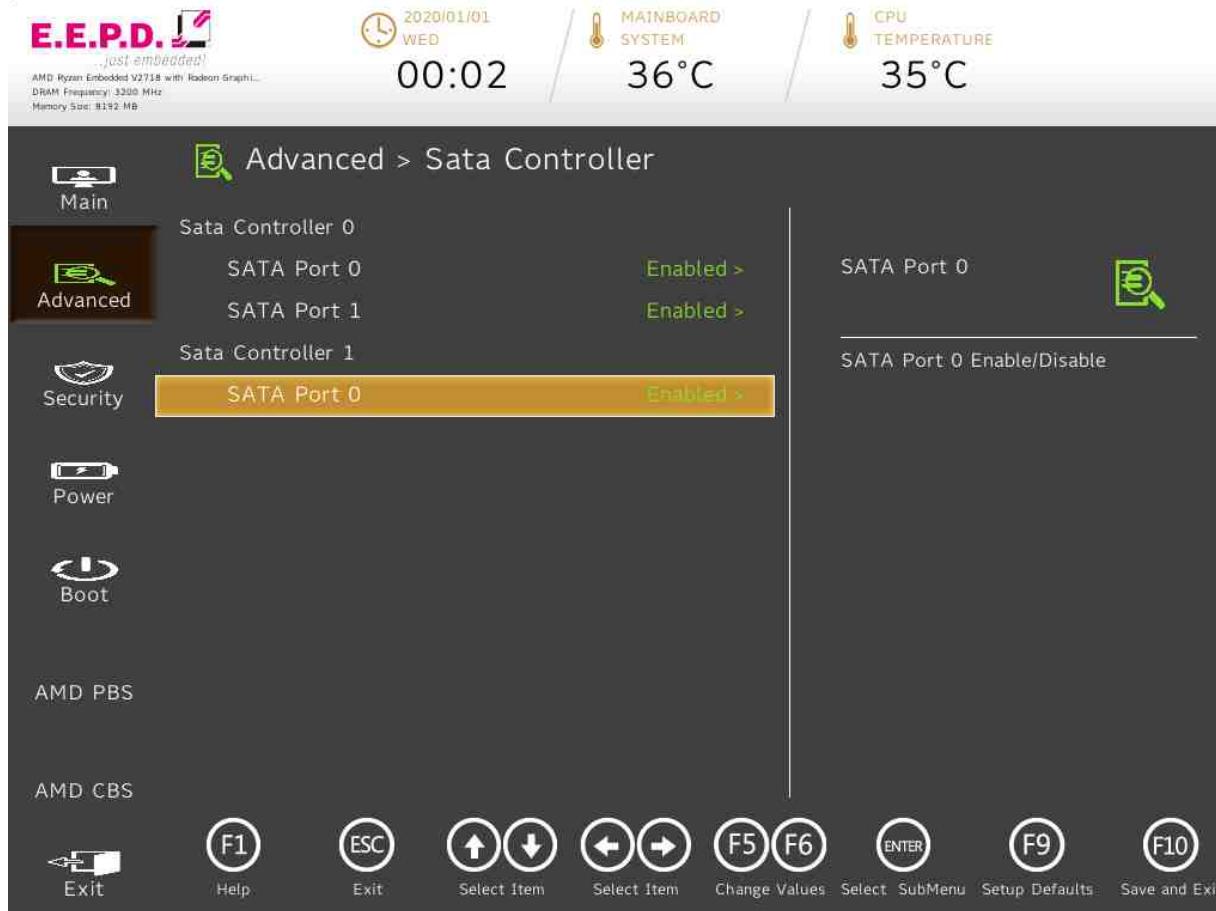


Fig. 64: SATA Controller

BIOS Settings	Options	Description
SATA Port 0	<Disabled> <Enabled>*	SATA Port 0 Enable/Disable
SATA Port 1	<Disabled> <Enabled>*	SATA Port 1 Enable/Disable
SATA Port 0	<Disabled> <Enabled>*	SATA Port 0 Enable/Disable

Tab. 19: SATA Controller 0

USB Configuration



Fig. 65: USB Configuration

BIOS Settings	Options	Description
Enable/Disable – VCC of USB Jacks	No options	Enable/Disable – USB VCC

Tab. 20: USB Configuration

**Enable/Disable – VCC of USB Jacks**

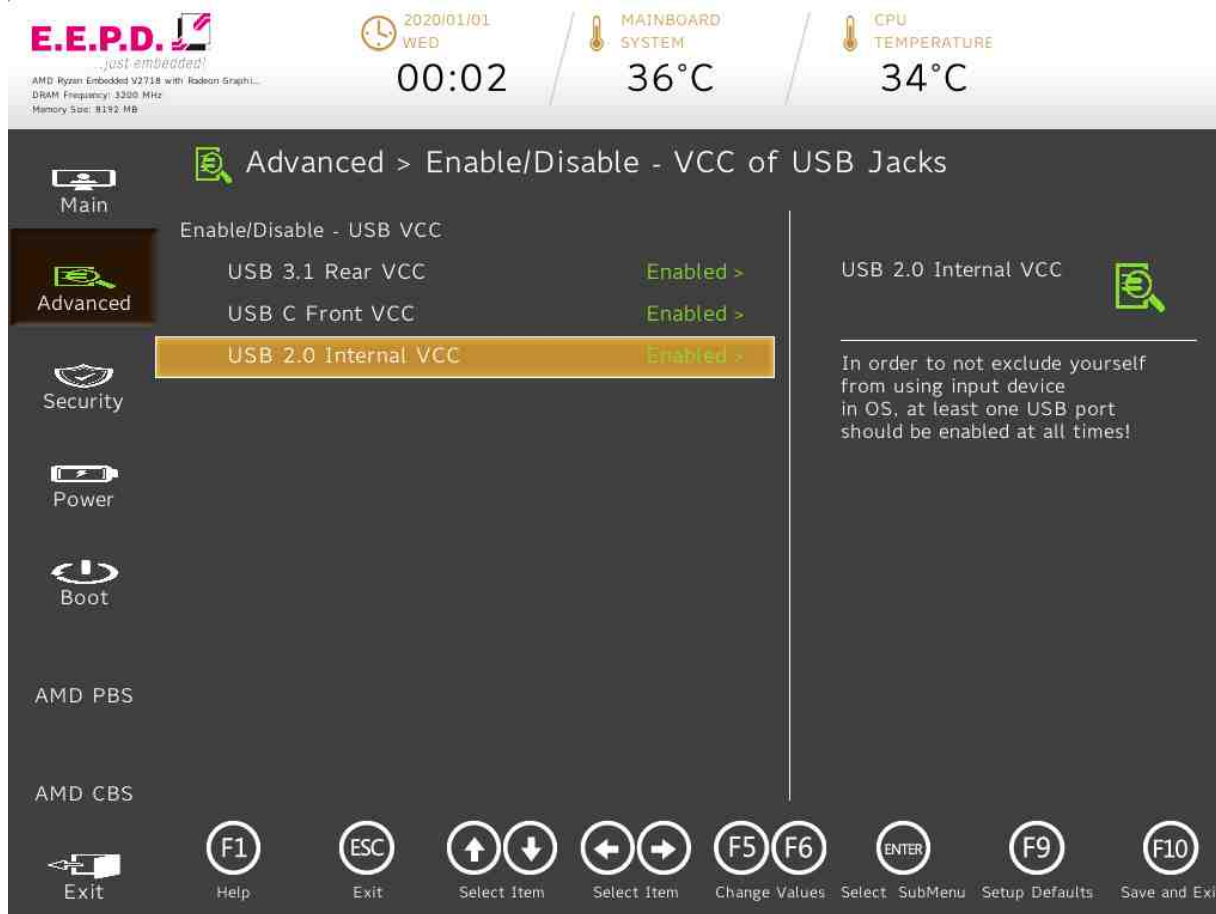


Fig. 66: USB Ports

BIOS Settings	Options	Description
USB 3.1 Rear VCC	<Disabled> <Enabled>*	In order to not exclude yourself from using input device in OS, at least one USB port should be enabled at all times!
USB C Front VCC	<Disabled> <Enabled>*	In order to not exclude yourself from using input device in OS, at least one USB port should be enabled at all times!
USB 2.0 Internal VCC	<Disabled> <Enabled>*	In order to not exclude yourself from using input device in OS, at least one USB port should be enabled at all times!

Tab. 21: USB Ports



Chipset Configuration

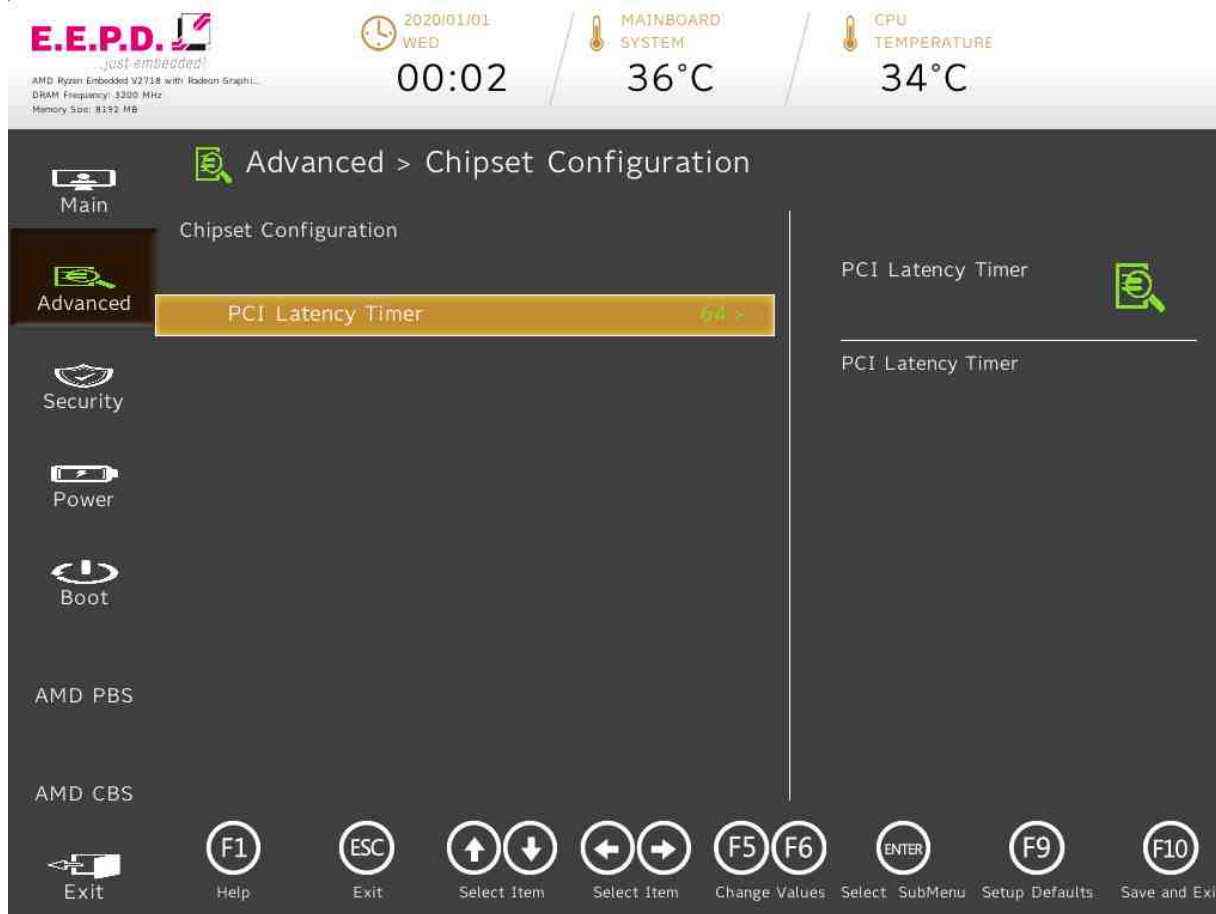


Fig. 67: Chipset Configuration

BIOS Settings	Options	Description
PCI Latency Timer	<32> <64>* <96> <128> <160> <192> <224> <248>	PCI Latency Timer

Tab. 22: Chipset Configuration

ACPI Table



Fig. 68: ACPI Table

BIOS Settings	Options	Description
HPET - HPET Support	<Disabled> <Enabled>*	High Precision Event Timer is supported in Windows Vista or above. HPET controller should not been seen in Windows XP no matter enable/disable in SCU. If this feature is enabled, the HPET table will be added into ACPI Tables.

Tab. 23: ACPI Table

CPU Related setting

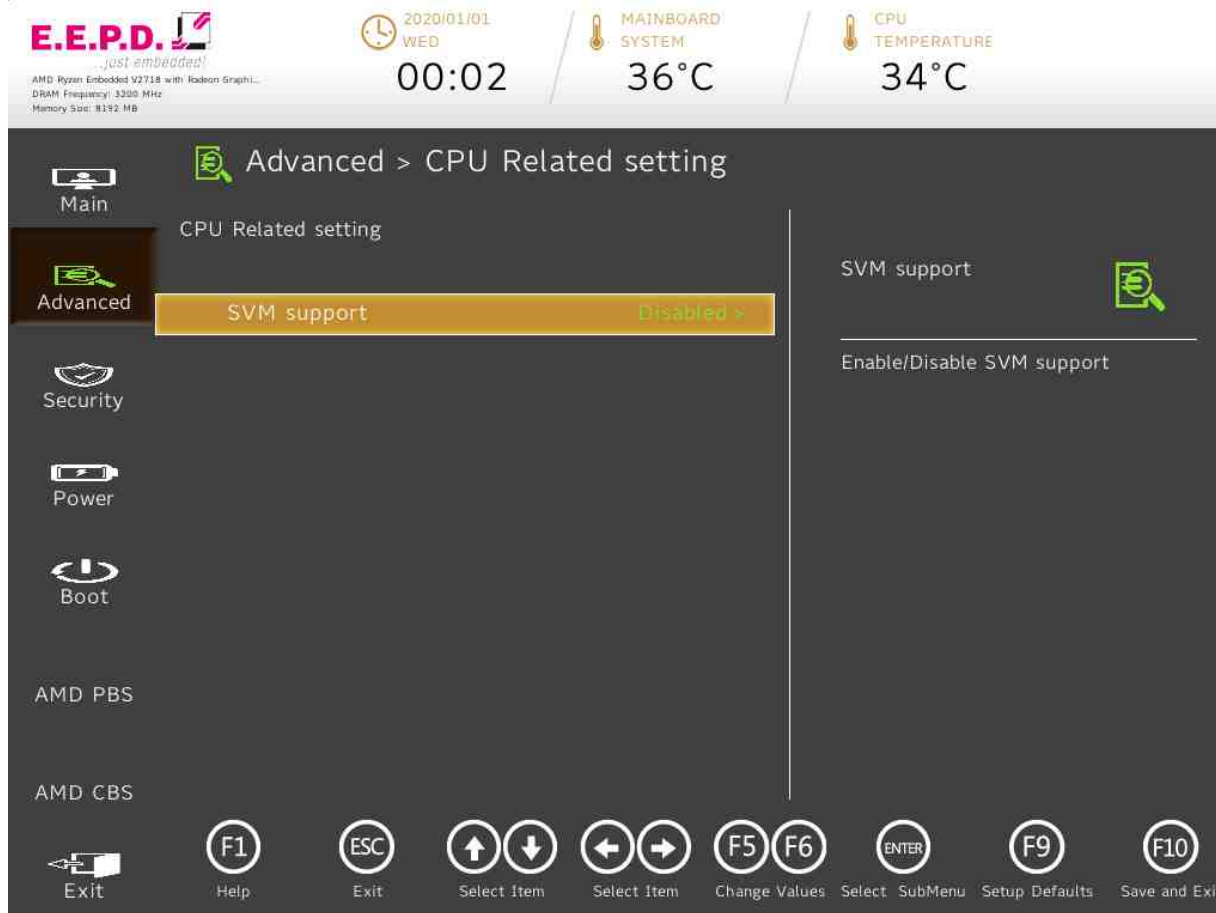


Fig. 69: CPU related setting

BIOS Settings	Options	Description
SVM support	<Disabled>* <Enabled>	Enable/Disable SVM support

Tab. 24: CPU Related setting

**NUCE options – Watchdog**

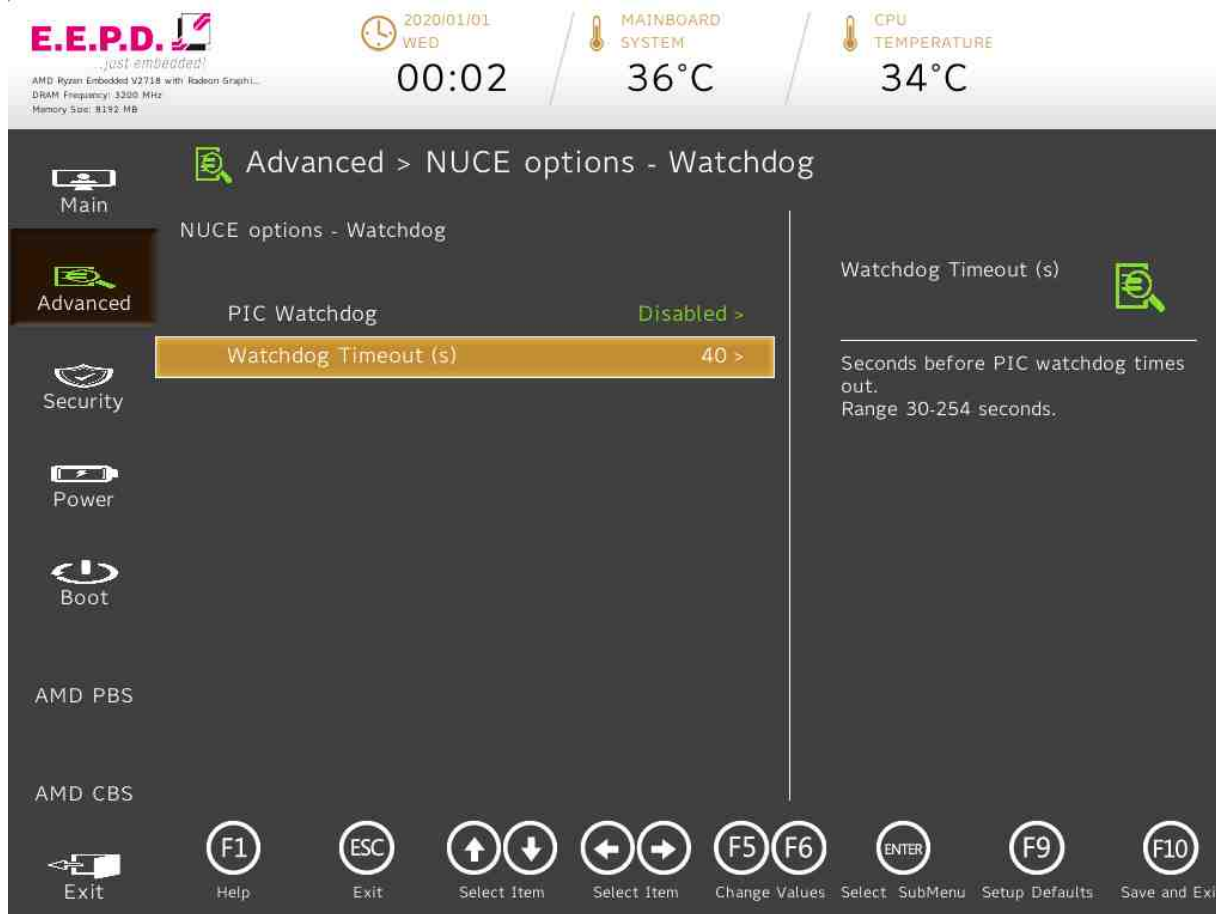


Fig. 70: NUCE options

BIOS Settings	Options	Description
PIC Watchdog	<Disabled>* <Enabled>	Enable/Disable the PIC watchdog
Watchdog Timeout (s)	Adjust value [30-254] Default value [40]	Seconds before PIC watchdog times out. Range 30-254 seconds.

Tab. 25: NUCE options



SIO SCH3223



Fig. 71: SIO SCH3223

BIOS Settings	Options	Description
UART Port 1 Configuration	No options	UART Configuration
UART Port 2 Configuration	No options	UART Configuration

Tab. 26: SIO SCH3223

UART Port 1 Configuration

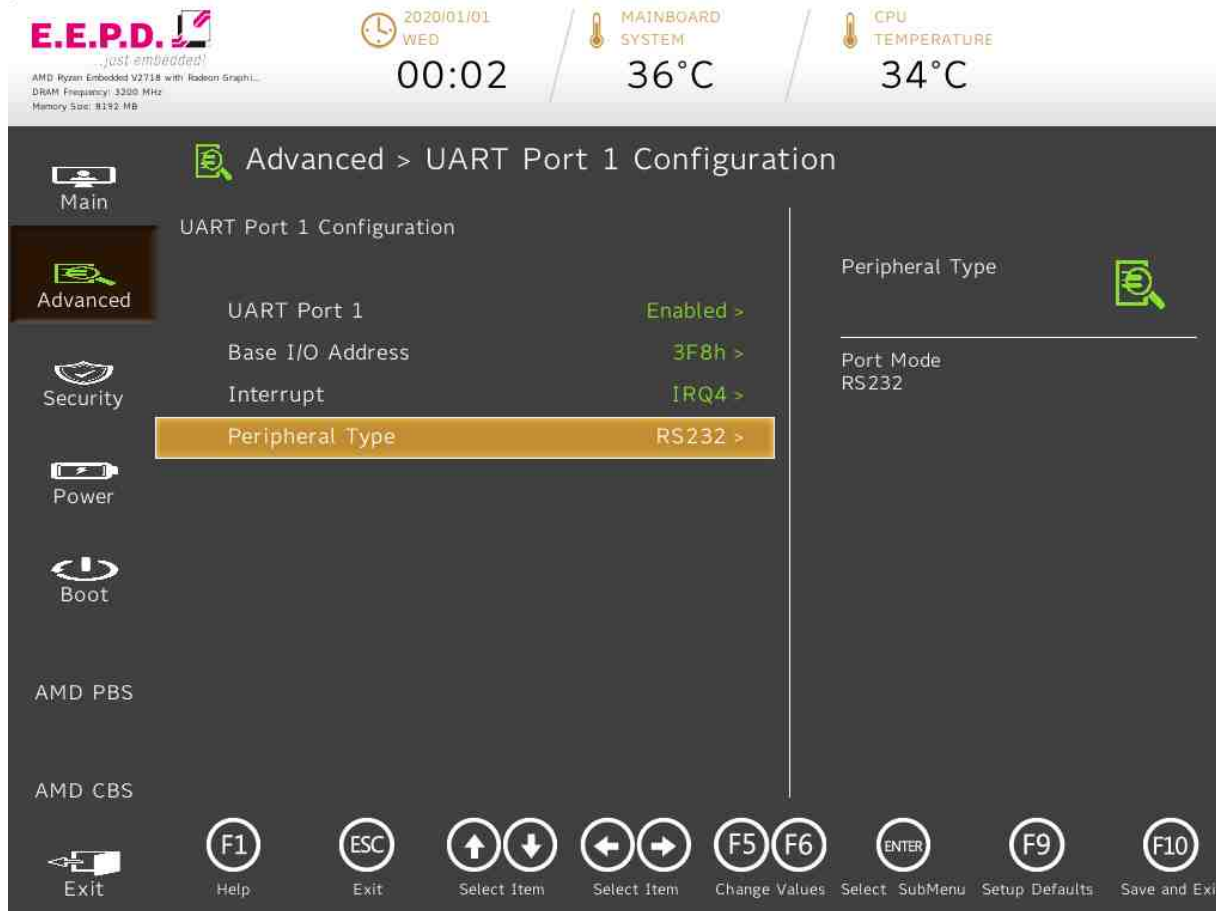


Fig. 72: UART Port 1 Configuration

BIOS Settings	Options	Description
UART Port 1	<Disabled> <Enabled>*	Configure UART port using options: [Disabled] Disable device [Enabled] Enable device and use below settings
Base I/O Address	<3F8h>* <2F8h> <3E8h> <2E8h> <338h> <228h> <220h> <238h>	System I/O base resources
Interrupt	<IRQ3> <IRQ4>* <IRQ6> <IRQ7> <IRQ11>	System interrupt resources
Peripheral Type	<RS232>*	Port Mode: RS232

Tab. 27: UART Port 1 Configuration

UART Port 2 Configuration



Fig. 73: UART Port 2 Configuration

BIOS Settings	Options	Description
UART Port 2	<Disabled> <Enabled>*	Configure UART port using options: [Disabled] Disable device [Enabled] Enable device and use below settings
Base I/O Address	<3F8h> <2F8h>* <3E8h> <2E8h> <338h> <228h> <220h> <238h>	System I/O base resources
Interrupt	<IRQ3>* <IRQ4> <IRQ6> <IRQ7> <IRQ11>	System interrupt resources
Peripheral Type	<RS232>*	Port Mode: RS232

Tab. 28: UART Port 2 Configuration

### 5.4 Security Menu

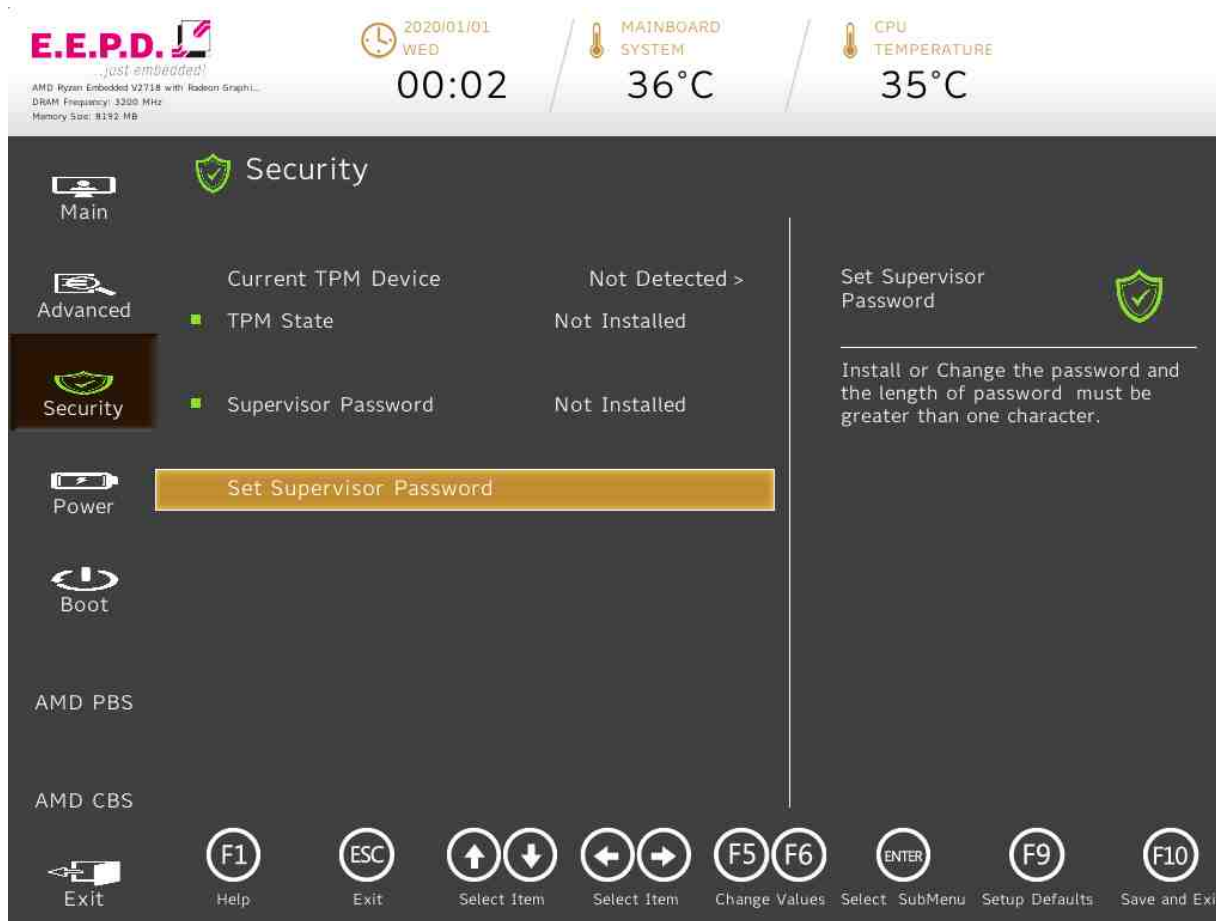


Fig. 74: Security Menu

BIOS Settings	Options	Description
Current TPM Device	<Not Detected> <TPM 1.2> <TPM 2.0>*	Current TPM Device: TPM1.2, or TPM2.0.
Set Supervisor Password	None	Install or Change the password and the length of password must be greater than one character.

Tab. 29: Security Menu 1



### 5.5 Power Menu



Fig. 75: Power Menu

BIOS Settings	Options	Description
Auto Wake on S5	<Disabled>* <By Every Day> <By Day of Month>	Auto wake on S5, By Day of Month or Fixed time of every day

Tab. 30: Power Menu

## 5.6 Boot Menu

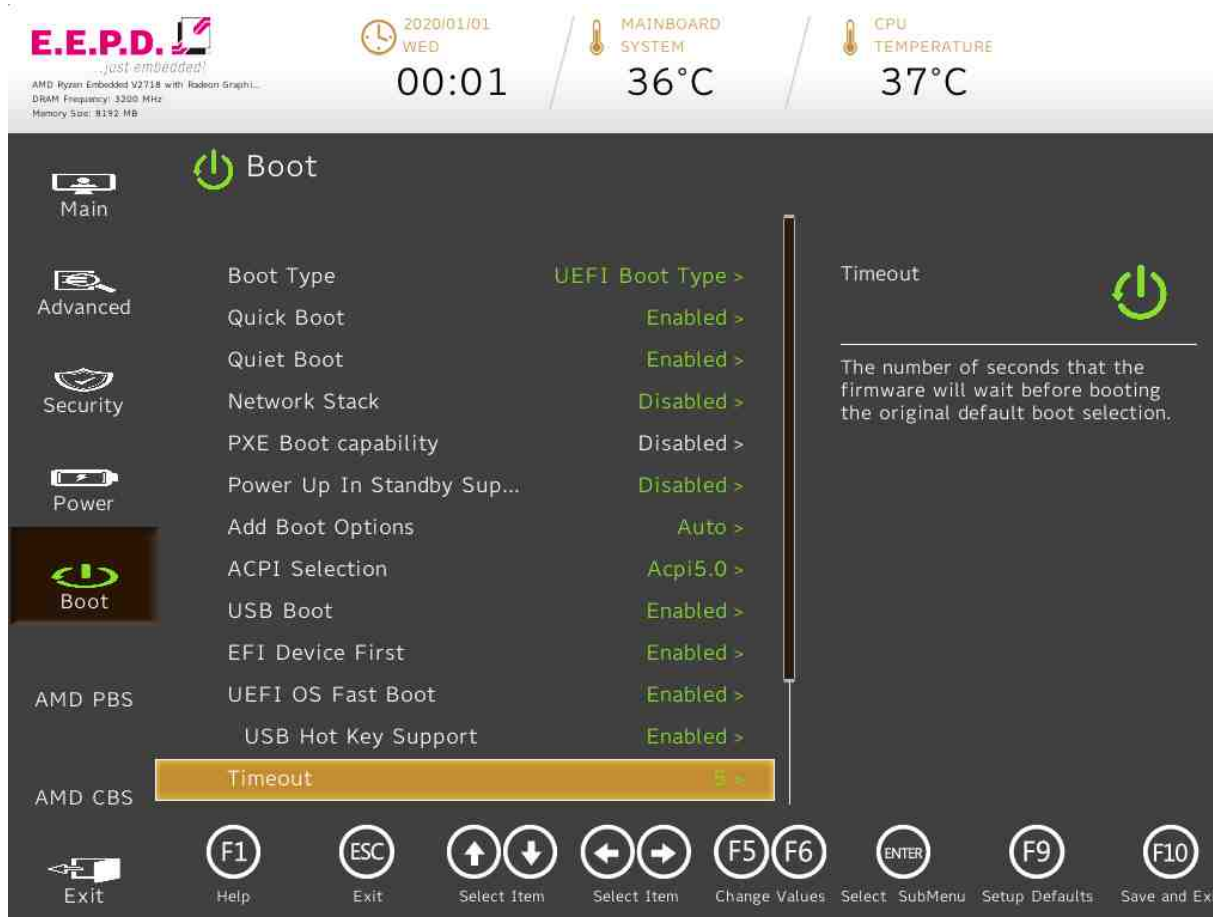


Fig. 76: Boot Menu 1

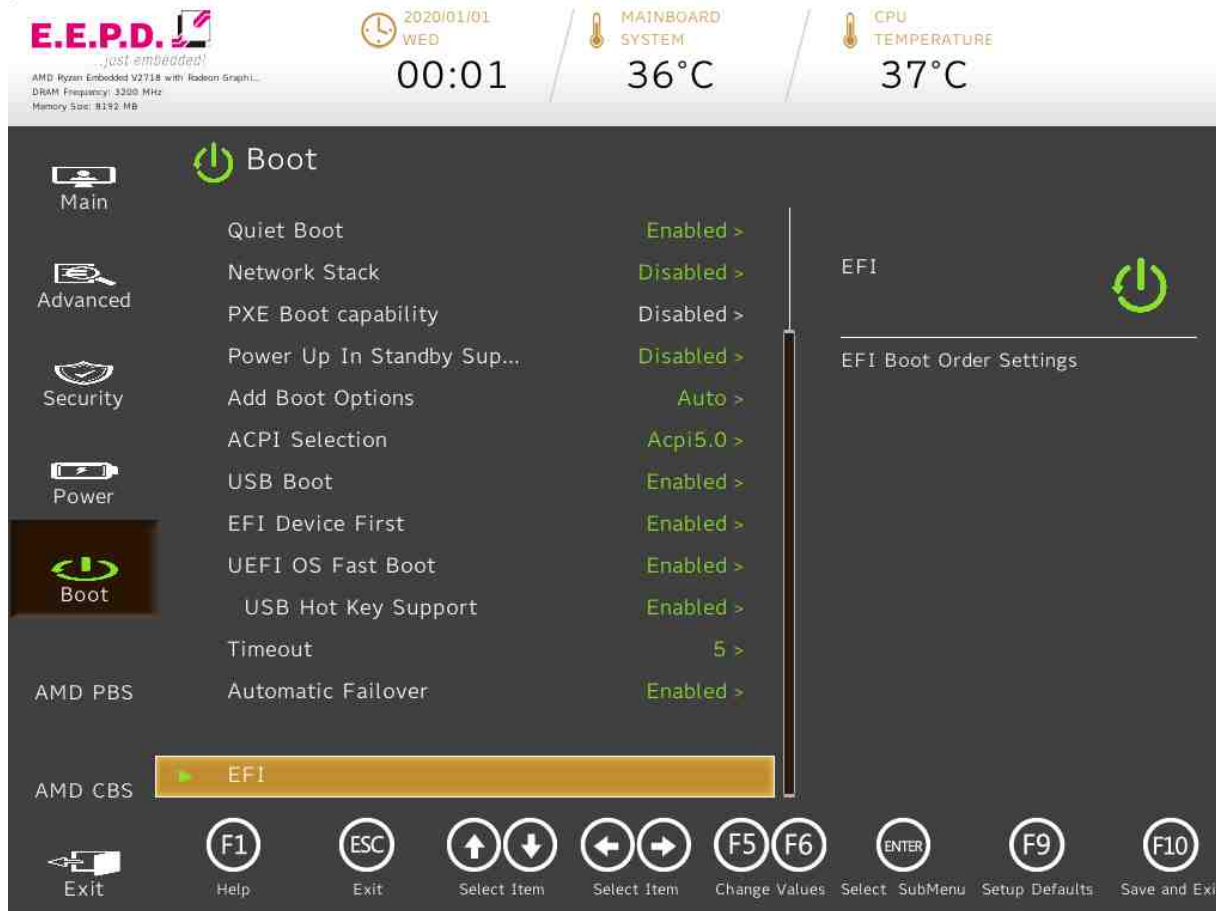


Fig. 77: Boot Menu 2

BIOS Settings	Options	Description
Boot Type	<Dual Boot Type> <Legacy Boot Type> <UEFI Boot Type>*	Select boot type to Dual type, Legacy type or UEFI type
Quick Boot	<Enabled>* <Disabled>	Allows InsydeH2O to skip certain tests while booting. This will decrease the time needed to boot the system.
Quiet Boot	<Enabled>* <Disabled>	Disables or enables booting in Text Mode.
Network Stack	<Disabled>* <Enabled>	Network Stack Support: Windows 8 BitLocker Unlock UEFI IPv4/IPv6 PXE Legacy PXE OPROM
PXE Boot capability	<Disabled>*	Disabled: Support Network Stack UEFI PXE: IPv4/IPv6 Legacy: Legacy PXE OPROM only
Power Up In Standby Support	<Enabled> <Disabled>*	Disable or enable Power Up in Standby Support. The PUIS feature set allows devices to be powered-up into the Standby power management state to minimize inrush current at power-up and to allow the host to sequence the spin-up of devices.
Add Boot Options	<First> <Last> <Auto>*	Position in Boot Order for Shell, Network and Removables
ACPI Selection	<Acpi4.0> <Acpi5.0>* <Acpi6.0> <Acpi6.1> <Acpi6.2> <Acpi6.3>	Select booting to Acpi3.0/Acpi1.0B
USB Boot	<Enabled>* <Disabled>	Disables or enables booting to USB boot devices.

EFI Device First	<Disabled> <Enabled>*	Determine EFI device first or legacy device first. If enable, it is EFI device first. If disable, it is Legacy device first.
UEFI OS Fast Boot	<Enabled>* <Disabled>	If enabled the system firmware does not initialize keyboard and check for firmware menu key.
USB Hot Key Support	<Disabled>* <Enabled>	Enable/Disable to support USB hot key while booting. This will decrease the time needed to boot the system.
Timeout	Adjust value [0-10] Default value [5]	The number of seconds that the firmware will wait before booting the original default boot selection.
Automatic Failover	<Disabled> <Enabled>*	Enable: if boot to default device fail, it will directly try to boot next device. Disable: if boot to default device fail, it will pop warning message then go into firmware UI.
EFI	No options	EFI Boot Order Settings

Tab. 31: Boot Menu

EFI

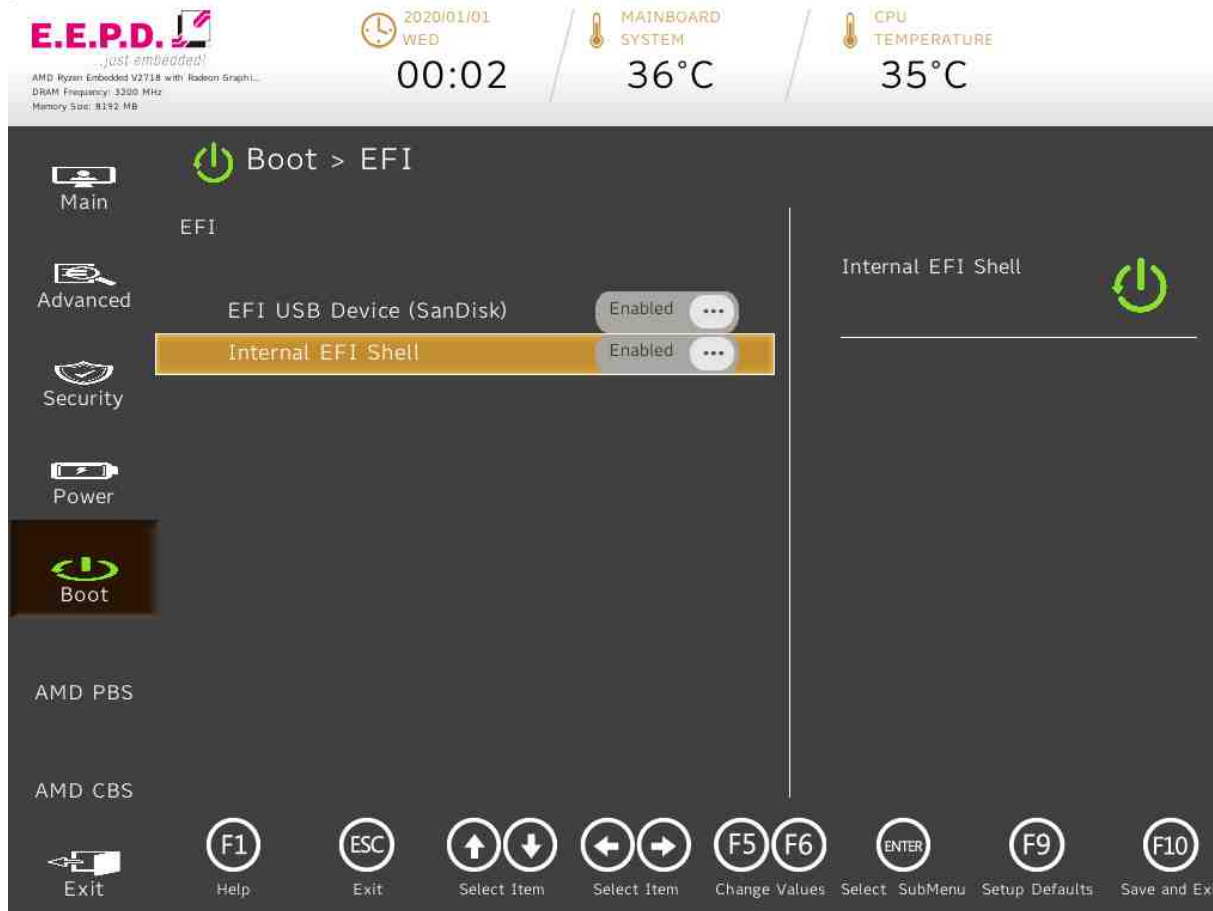


Fig. 78: EFI

BIOS Settings	Options	Description
EFI USB Device (SanDisk)	[ ]* [X]	
Internal EFI Shell	[ ]* [X]	

Tab. 32: EFI



### 5.7 AMD PBS Menu



Fig. 79: AMD PBS Option

BIOS Settings	Options	Description
AMD Firmware Version	No options	Show all of AMD Firmware Version
M.2 Key M SATA/PCIE Selection	<Force PCIE> <Force SATA> <Auto Detection>*	M.2 Key M SATA/PCIE Selection usage: SATA, PCIE or Auto Detection
M.2 Key B Power Enable	<Disabled> <Enabled>*	Enable/Disable power of M.2 Key B Slot
M.2 Key E Power Enable	<Disabled> <Enabled>*	Enable/Disable power of M.2 Key E Slot
Above 4GB MMIO Limit	<35bit (32GB)> <36bit (64GB)> <37bit (128GB)> <38bit (256GB)> <39bit (512GB)> <40bit (1TB)>* <41bit (2TB)> <42bit (4TB)> <43bit (8TB)> <44bit (16TB)> <45bit (32TB)> <46bit (64TB)> <47bit (128TB)> <48bit (256TB)>	Select Above 4GB MMIO Limit to 35~48bits limit.
S3/Modern Standby Support	<S3 Enable>* <Modern Standby Enable>	Switch S3/Modern Standby
Wake on PME	<Disabled> <Enabled>*	Determines the action taken when the system power is off and a PCI Power Management Enable wake up event occurs.

Tab. 33: AMD PBS Option

AMD Firmware Version

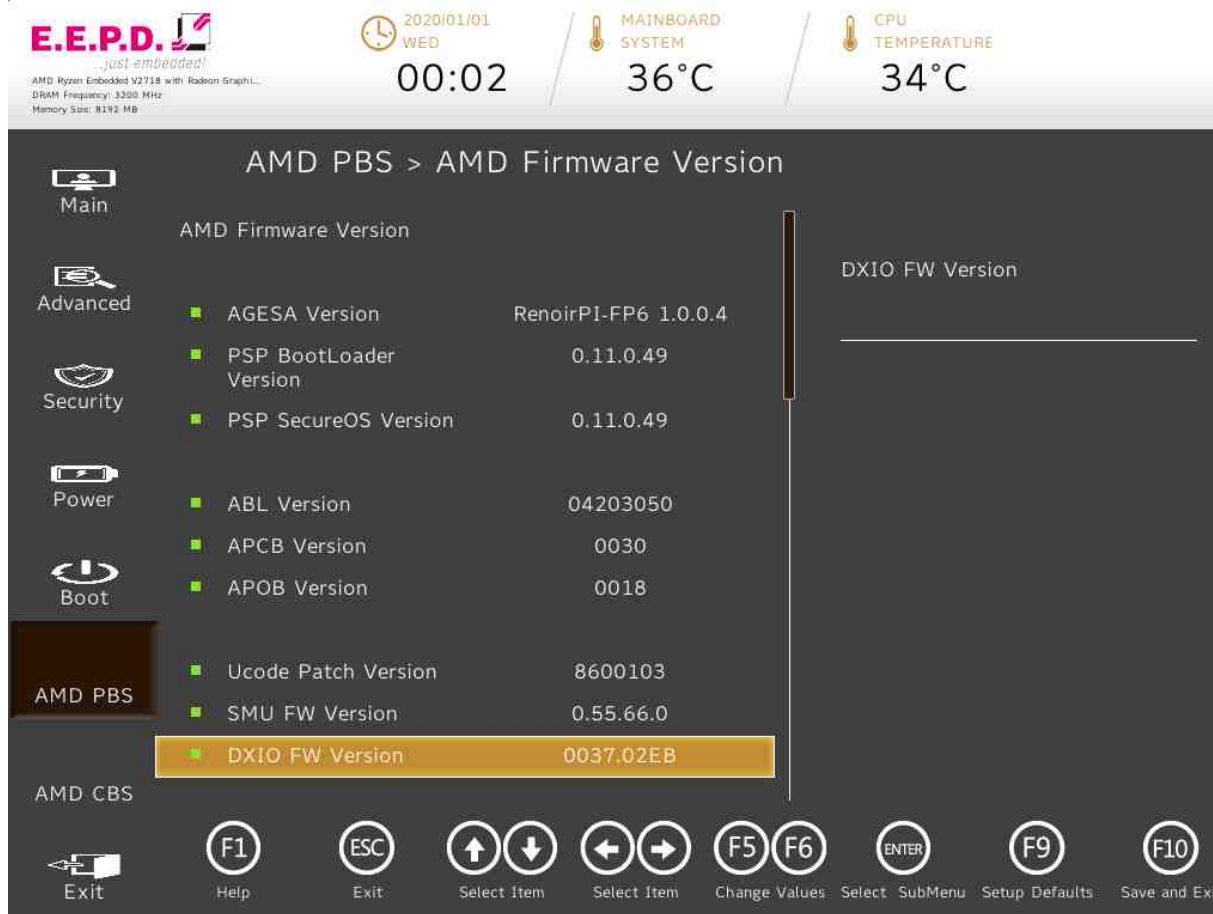


Fig. 80: AMD Firmware Version 1

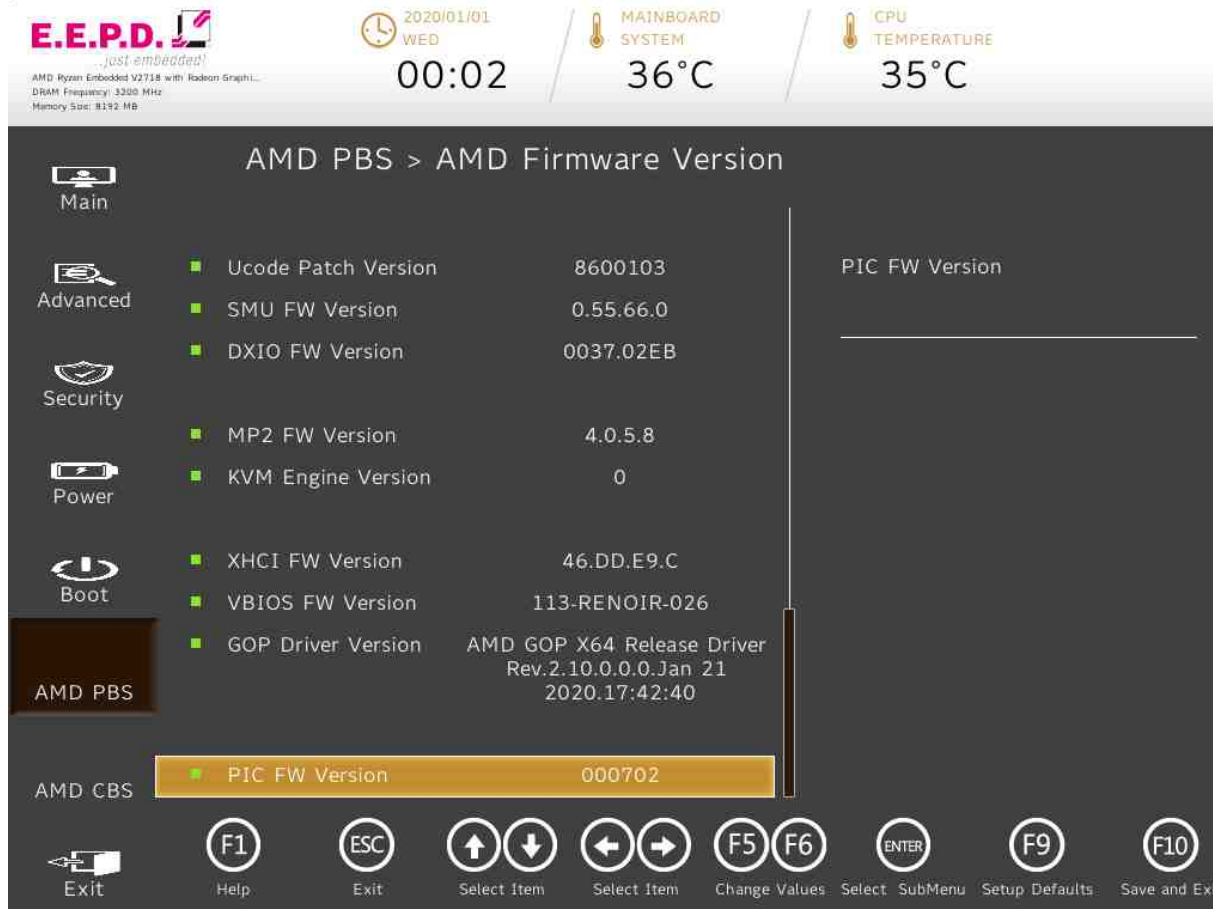


Fig. 81: AMD Firmware Version 2

### 5.8 AMD CBS Menu



Fig. 82: AMD CBS

BIOS Settings	Options	Description
CPU Common Options	No options	CPU Common Options
NBIO Common Options	No options	NBIO Common Options
FCH Common Options	No options	FCH Common Options

Tab. 34: AMD CBS

CPU Common Options

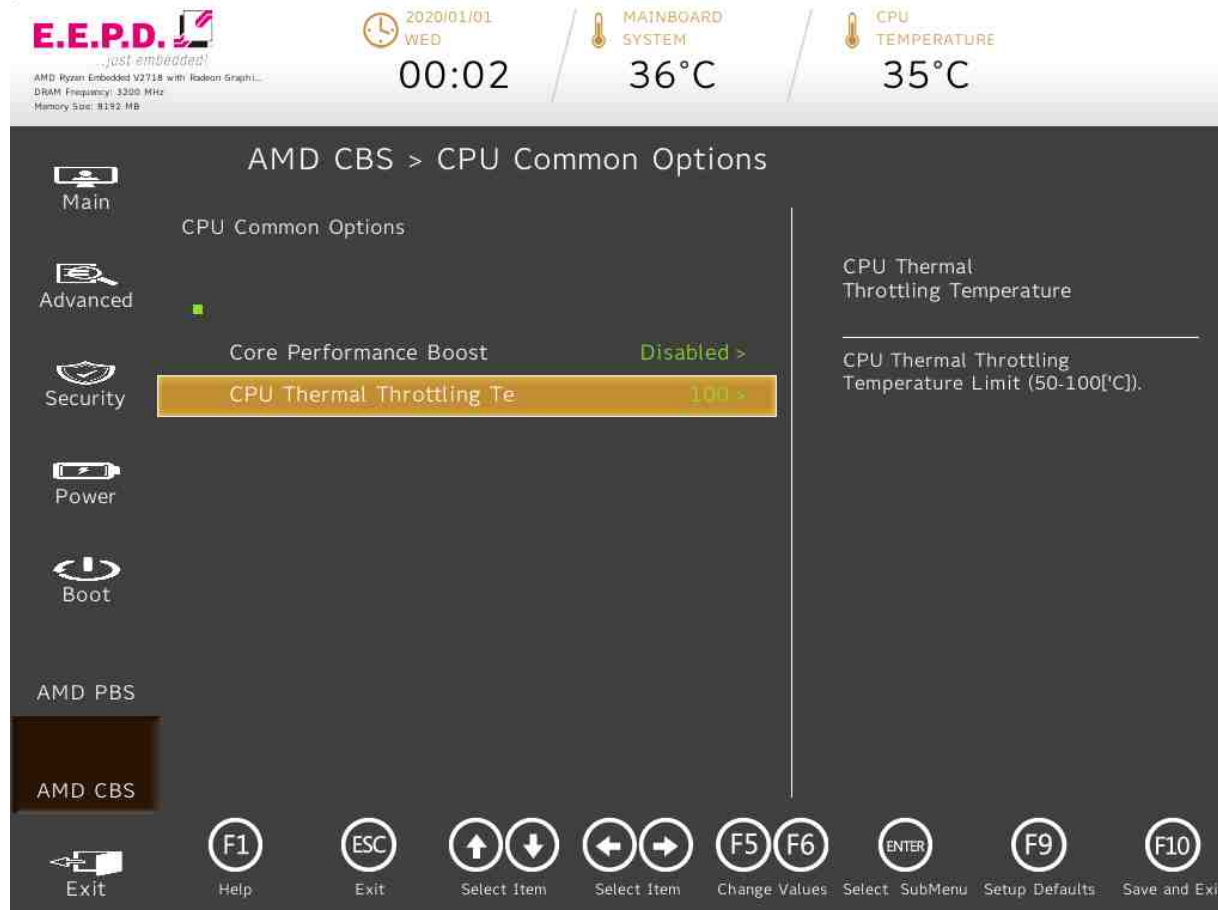


Fig. 83: CPU Common Options

BIOS Settings	Options	Description
Core Performance Boost	<Disabled>* <Auto>	Disable CPB
CPU Thermal Throttling Temperature	Adjust value [50-100] Default value [100]	CPU Thermal Throttling Temperature Limit (50-100[°C])

Tab. 35: CPU Common Options



**NBIO Common Options**



Fig. 84: NBIO Common Options

BIOS Settings	Options	Description
GFX Configuration	No options	GFX Configuration
SMU Common Options	No options	SMU Common Options

Tab. 36: NBIO Common Options

## GFX Configuration

Under this setting, the allocation of RAM memory to GPU memory can be changed:  
iGPU Configuration → <UMA\_SPECIFIED> → UMA Frame buffer size 2G.

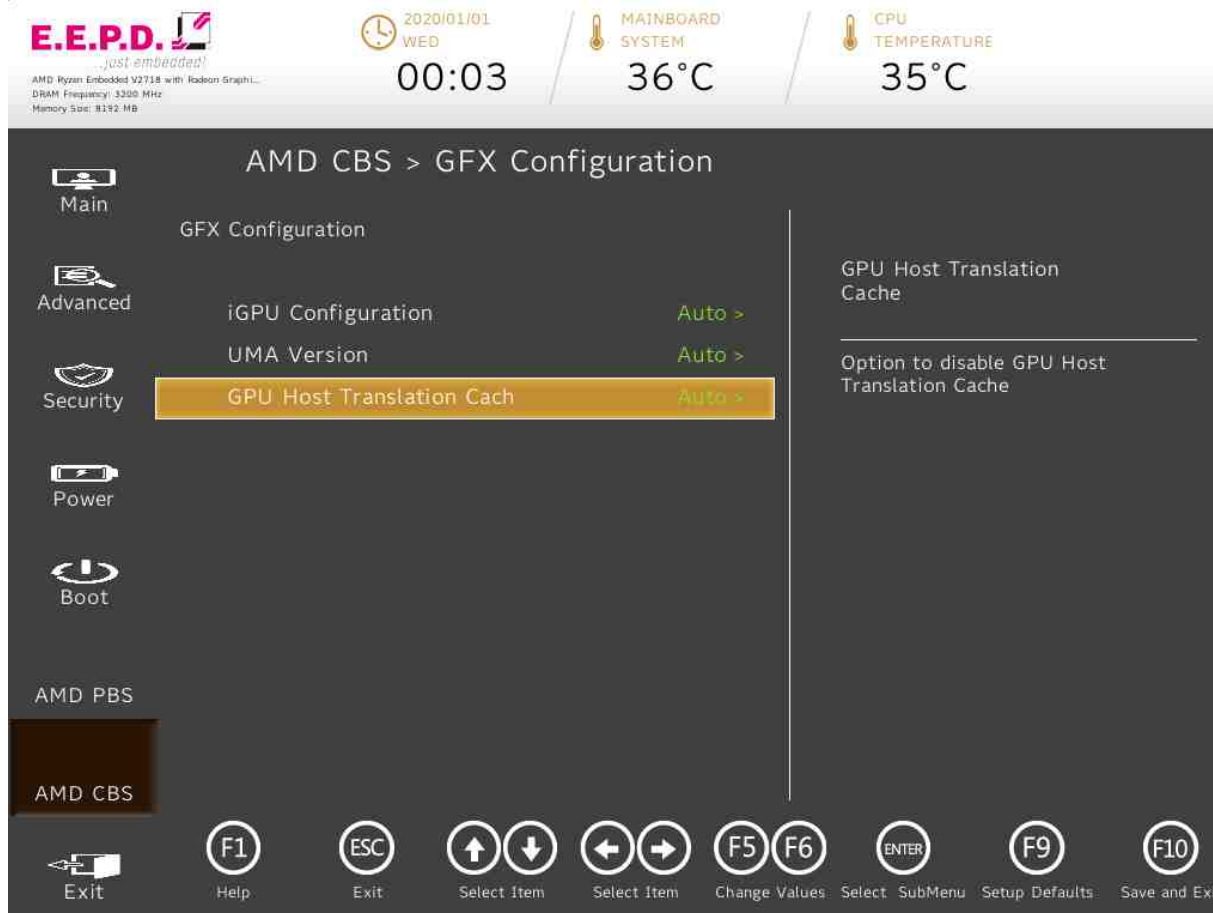


Fig. 85: GFX Configuration

BIOS Settings	Options	Description
iGPU Configuration	<Auto> <iGPU Disabled> <UMA_SPECIFIED> <UMA_AUTO> <UMA_GAME_OPTIMIZED>	UMA Mode
UMA Version	<Legacy> <Non-Legacy> <Hybrid Secure> <Auto>	UMA Legacy Version UMA Non-Legacy Version Hybrid Secure
GPU Host Translation Cache	<Disabled> <Enabled> <Auto>	Option to disable GPU Host Translation Cache

Tab. 37: GFX Configuration

SMU Common Options

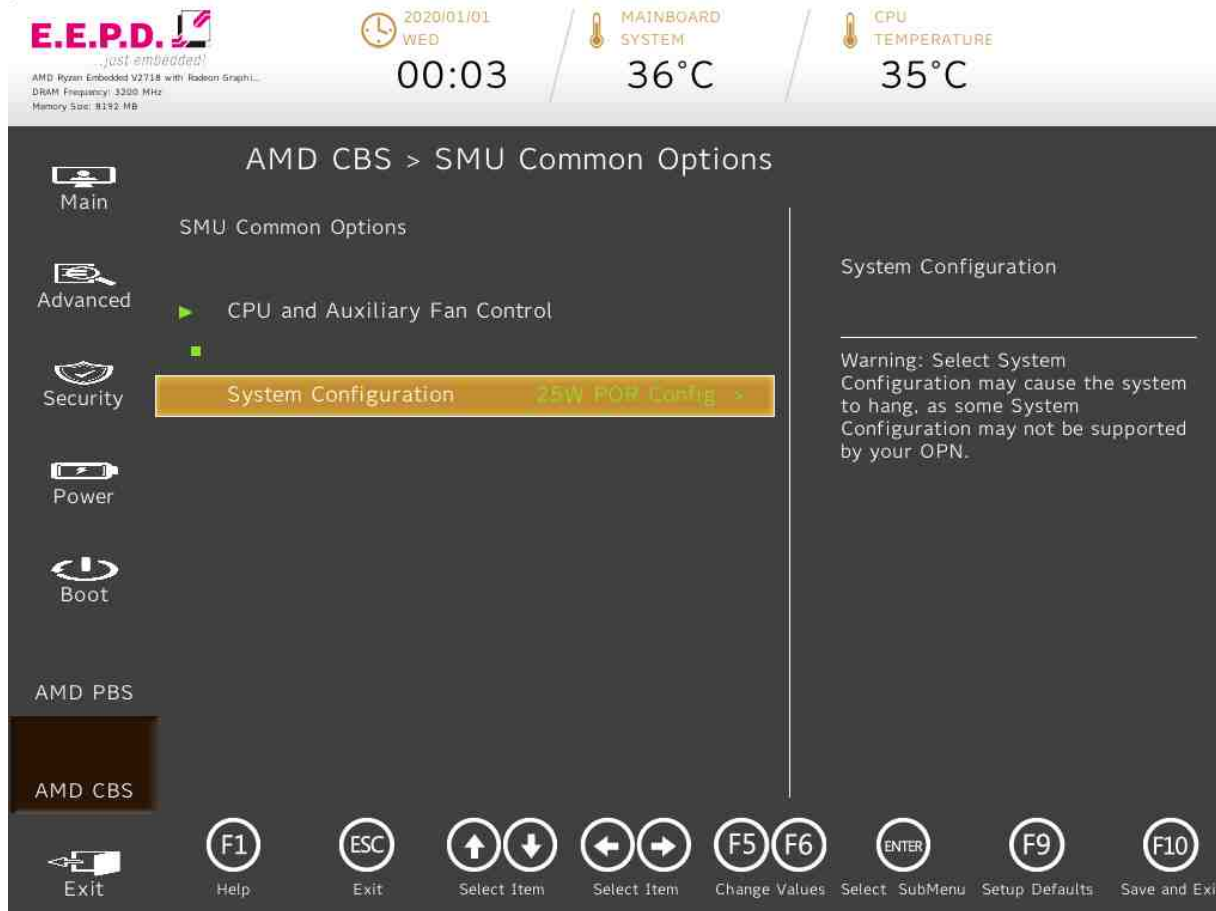


Fig. 86:SMU Common Options

BIOS Settings	Options	Description
CPU and Auxiliary Fan Control	No options	CPU and Auxiliary Fan Control
System Configuration	<15W POR Configuration> <18W POR Configuration> <25W POR Configuration>	Warning: Select System Configuration may cause the system to hang, as some System Configuration may not be supported by your OPN.

Tab. 38: SMU Common Options

CPU and Auxiliary Fan Control

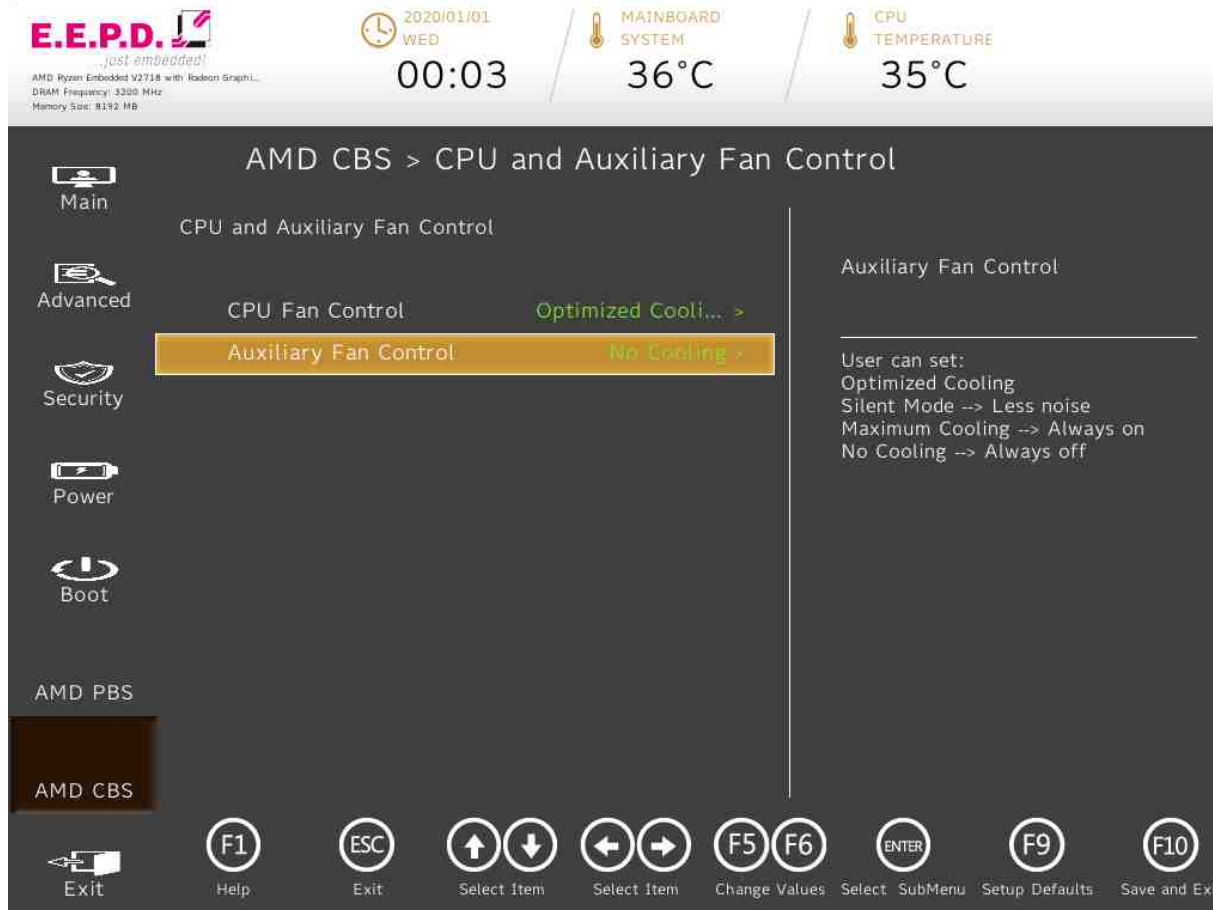


Fig. 87: CPU and Auxiliary Fan Control

BIOS Settings	Options	Description
CPU Fan Control	<Optimized Cooling>* <Silent Mode> <Maximum Cooling> <No Cooling>	User can set: Optimized Cooling Silent Mode → Less noise Maximum Cooling → Always on No Cooling → Always off
Auxiliary Fan Control	<Optimized Cooling> <Silent Mode> <Maximum Cooling> <No Cooling>*	User can set: Optimized Cooling Silent Mode → Less noise Maximum Cooling → Always on No Cooling → Always off

Tab. 39: CPU and Auxiliary Fan Control



FCH Common Options



Fig. 88: FCH Common Options

BIOS Settings	Options	Description
USB Configuration Options	No options	USB Configuration Options
Ac Power Loss Options	No options	Ac Power Loss Options

Tab. 40: FCH Common Options

USB Configuration Options

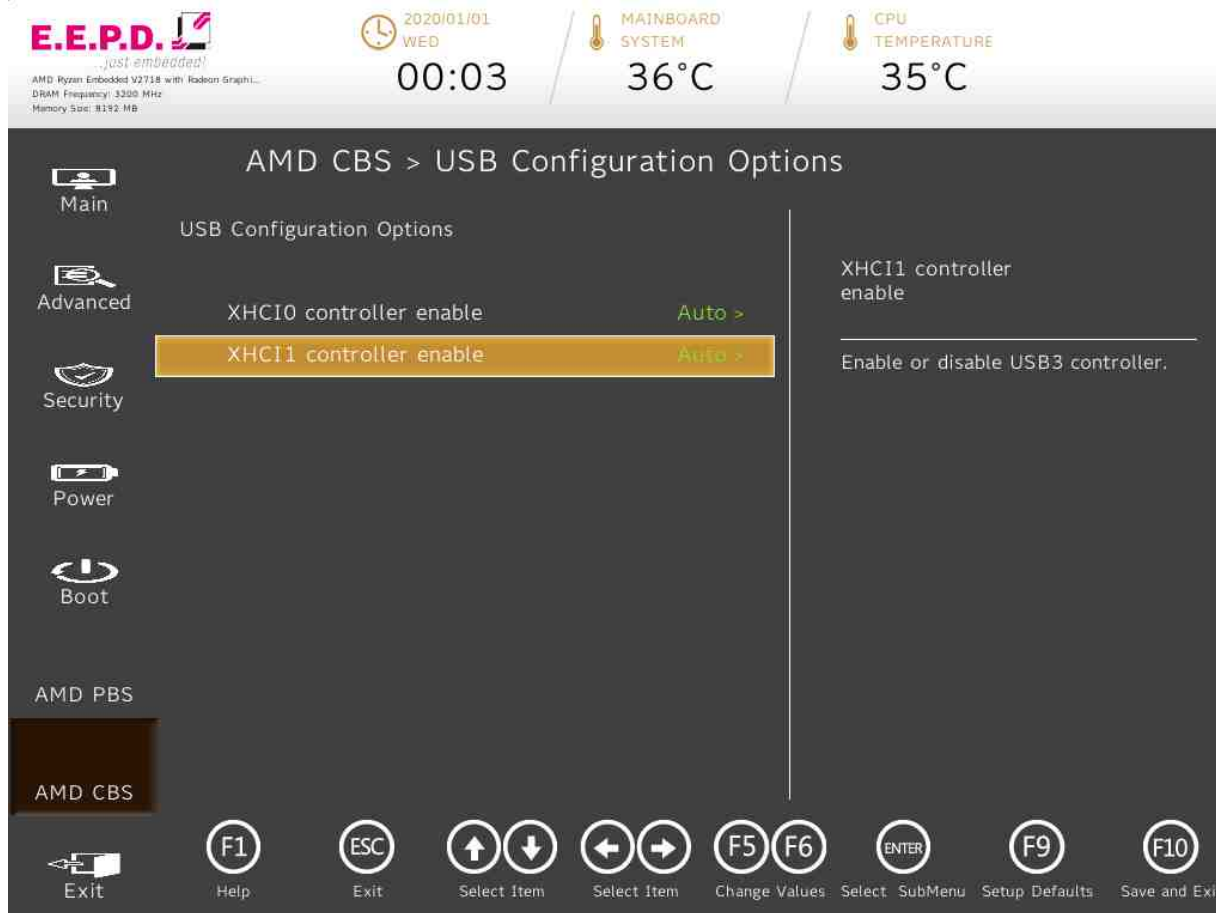


Fig. 89: USB Configuration Options

BIOS Settings	Options	Description
XHCI0 controller enable	<Enabled> <Disabled> <Auto>*	Enable or disable USB3 controller.
XHCI1 controller enable	<Enabled> <Disabled> <Auto>*	Enable or disable USB3 controller.

Tab. 41: USB Configuration Options

Ac Power Loss Options



Fig. 90: Ac Power Loss Options

BIOS Settings	Options	Description
Ac Loss Control	<Always Off> <Always On> <Reserved> <Previous>* <Auto>	Select Ac Loss Control Method

Tab. 42: Ac Power Loss Options

### 5.9 Exit Menu

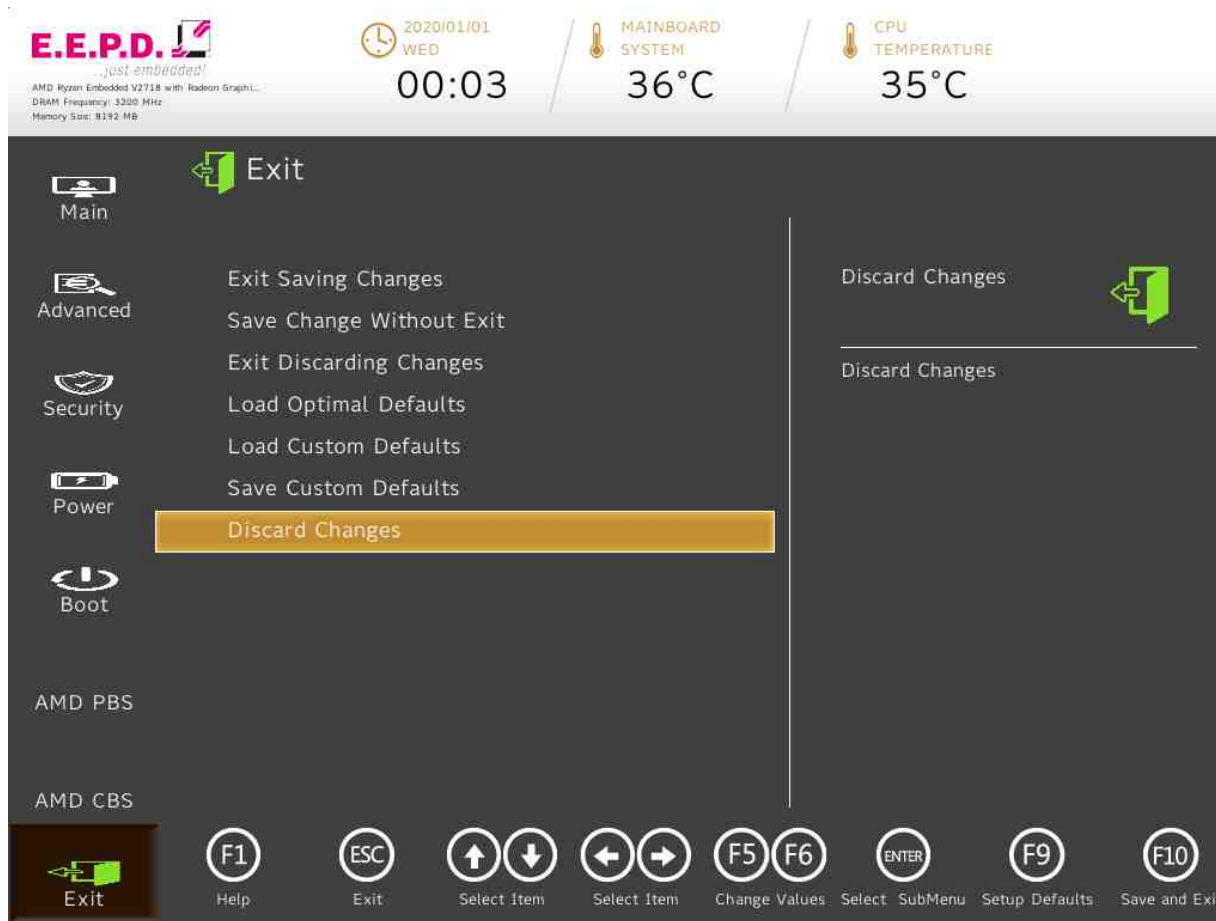


Fig. 91: Exit Menu

BIOS Settings	Options	Description
Exit Saving Changes		Exit system setup and save your changes.
Save Change Without Exit		Save your changes and without exiting system.
Exit Discarding Changes		Exit system setup and without saving your changes.
Load Optimal Defaults		Load Optimal Defaults.
Load Custom Defaults		Load Custom Defaults.
Save Custom Defaults		Save Custom Defaults
Discard Changes		Discard Changes

Tab. 43: Exit Menu



## Revision History

Date	Version	Changes
26.02.2021	1.0	First release
08.04.2021	1.1	BIOS Update
13.04.2021	1.2	BIOS Update
16.04.2021	1.3	Some corrections and updates
01.06.2021	1.4	BIOS Update
30.06.2021	1.5	BIOS Update and some corrections
31.08.2021	1.6	BIOS Update and splitting in 25W and 54W version
20.10.2021	1.7	Some corrections and updates

## Index of Figures

Fig. 1: System Overview.....	10	Fig. 30: M.2 Key E Connector Detail .....	25
Fig. 2: Top View.....	12	Fig. 31: M.2 Key B Connector Detail .....	25
Fig. 3: Bottom View.....	12	Fig. 32: USB-C Port Detail.....	26
Fig. 4: Front View.....	13	Fig. 33: USB-C Port Schematic .....	26
Fig. 5: Recommended cutouts front panel.....	13	Fig. 34: Audio Jack Detail .....	26
Fig. 6: Rear View .....	13	Fig. 35: STL3X1 Detail.....	27
Fig. 7: Recommended cutouts rear panel .....	13	Fig. 36: STL3X1 Schematic .....	27
Fig. 8: Side View .....	14	Fig. 37: SATA Data Connector Detail .....	28
Fig. 9: Mechanical Mounting.....	15	Fig. 38: SATA Data Connector Schematic .....	28
Fig. 10: Dimensions bottom side .....	16	Fig. 39: Molex SATA Power Connector Detail.....	28
Fig. 11: Dimensions top side .....	16	Fig. 40: Molex SATA Power Connector Schematic .....	28
Fig. 12: Dimensions front side .....	17	Fig. 41: eDP Connector Detail .....	29
Fig. 13: Dimensions side .....	17	Fig. 42: eDP Connector Schematic .....	29
Fig. 14: Dimensions threaded bolts .....	17	Fig. 43: Power Button/Power and SATA LEDs Detail .....	30
Fig. 15: Mini-DP Connector Detail .....	19	Fig. 44: Molex Reset Connector Detail.....	30
Fig. 16: Mini-DP Connector Schematic .....	19	Fig. 45: Molex Reset Connector Schematic .....	30
Fig. 17: Dual-USB 3.1 Port Detail.....	20	Fig. 46: Molex Power Button Connector Detail.....	31
Fig. 18: Dual-USB 3.1 Port Schematic .....	20	Fig. 47: Molex Power Button Connector Schematic .....	31
Fig. 19: Ethernet Dual-Port Detail.....	20	Fig. 48: Molex SoC FAN Connector Detail .....	32
Fig. 20: Ethernet Port Schematic.....	20	Fig. 49: Molex SSD FAN Connector Detail.....	32
Fig. 21: Power Connector Detail.....	21	Fig. 50: Molex FAN Connector Schematic.....	32
Fig. 22: Power Connector Schematic .....	21	Fig. 51: Molex RS232/485 Connector Detail .....	33
Fig. 23: DDR4 SODIMM Socket Detail.....	22	Fig. 52: Molex RS232/485 Connector Schematic.....	33
Fig. 24: RAM Assembly .....	22	Fig. 53: Molex Feature Connector Detail.....	34
Fig. 25: Molex Battery Connector Detail.....	23	Fig. 54: Molex Feature Connector Schematic .....	34
Fig. 26: Molex Battery Connector Schematic .....	23	Fig. 55: Molex USB internal Connector Detail .....	35
Fig. 27: Molex Audio Connector Detail.....	24	Fig. 56: Molex USB internal Connector Schematic .....	35
Fig. 28: Molex Audio Connector Schematic .....	24	Fig. 57: Main Menu 1 .....	37
Fig. 29: M.2 Key M Connector Detail.....	25	Fig. 58: Main Menu 2 .....	38
		Fig. 59: Advanced Menu .....	40
		Fig. 60: PCI Express Configurations.....	42
		Fig. 61: Boot Configuration .....	44

Fig. 62: Peripheral Configuration .....	46
Fig. 63: IDE Configuration .....	48
Fig. 64: SATA Controller .....	50
Fig. 65: USB Configuration .....	52
Fig. 66: USB Ports .....	54
Fig. 67: Chipset Configuration .....	56
Fig. 68: ACPI Table .....	58
Fig. 69: CPU related setting.....	60
Fig. 70: NUCE options .....	62
Fig. 71: SIO SCH3223 .....	64
Fig. 72: UART Port 1 Configuration .....	66
Fig. 73: UART Port 2 Configuration .....	68
Fig. 74: Security Menu.....	70
Fig. 76: Power Menu.....	72
Fig. 77: Boot Menu 1 .....	74
Fig. 78: Boot Menu 2 .....	75
Fig. 79: EFI .....	78
Fig. 80: AMD PBS Option .....	80
Fig. 81: AMD Firmware Version 1 .....	82
Fig. 82: AMD Firmware Version 2 .....	83
Fig. 83: AMD CBS .....	84
Fig. 84: CPU Common Options .....	86
Fig. 85: NBIO Common Options .....	88
Fig. 86: GFX Configuration .....	90
Fig. 87:SMU Common Options.....	92
Fig. 88: CPU and Auxiliary Fan Control.....	94
Fig. 89: FCH Common Options .....	96
Fig. 90: USB Configuration Options .....	98
Fig. 91: Ac Power Loss Options .....	100
Fig. 92: Exit Menu .....	102

## Index of Tables

Tab. 1: Power Connector.....	21	Tab. 31: Power Menu.....	73
Tab. 2: Battery Connector.....	23	Tab. 32: Boot Menu .....	77
Tab. 3: Audio Connector.....	24	Tab. 33: EFI .....	79
Tab. 4: STL3X1.....	27	Tab. 34: AMD PBS Option .....	81
Tab. 5: Molex SATA Power Connector.....	28	Tab. 35: AMD CBS .....	85
Tab. 6: eDP Connector .....	29	Tab. 36: CPU Common Options .....	87
Tab. 7: Molex Reset Connector.....	30	Tab. 37: NBIO Common Options.....	89
Tab. 8: Molex Power Button Connector.....	31	Tab. 38: GFX Configuration.....	91
Tab. 9: Molex FAN Connectors .....	32	Tab. 39: SMU Common Options.....	93
Tab. 10: Molex RS232/485 Connectors .....	33	Tab. 40: CPU and Auxiliary Fan Control.....	95
Tab. 11: Molex Feature Connector .....	34	Tab. 41: FCH Common Options .....	97
Tab. 12: Molex USB internal Connector .....	35	Tab. 42: USB Configuration Options .....	99
Tab. 13: Main Menu.....	39	Tab. 43: Ac Power Loss Options .....	101
Tab. 14: Advanced Menu.....	41	Tab. 44: Exit Menu.....	103
Tab. 15: PCI Express Configuration .....	43		
Tab. 16: Boot Configuration.....	45		
Tab. 17: Peripheral Configuration.....	47		
Tab. 18: IDE Configuration .....	49		
Tab. 19: SATA Controller 0 .....	51		
Tab. 20: USB Configuration.....	53		
Tab. 21: USB Ports.....	55		
Tab. 22: Chipset Configuration.....	57		
Tab. 23: ACPI Table .....	59		
Tab. 24: CPU Related setting.....	61		
Tab. 25: NUCE options.....	63		
Tab. 26: SIO SCH3223.....	65		
Tab. 27: UART Port 1 Configuration.....	67		
Tab. 28: UART Port 2 Configuration.....	69		
Tab. 29: Security Menu 1.....	71		

## Terminology

<b>BT</b> .....	Bluetooth
<b>CPU</b> .....	Central Processing Unit or processor
<b>DC</b> .....	Direct Current
<b>DDR4</b> .....	Fourth generation „Double Data Rate“ memory technology
<b>DP</b> .....	Display port
<b>EMI</b> .....	ElectroMagnetic Interference
<b>Gigabit Ethernet</b> .....	Ethernet connection with a frame transfer speed up to 1000 Mbit/s
<b>GND</b> .....	Ground
<b>MIC</b> .....	Microphone
<b>M.2</b> .....	Next generation mSATA
<b>PWM</b> .....	Pulse-Width Modulation
<b>RAM</b> .....	Random Access Memory
<b>RS-232</b> .....	Serial standard interface
<b>RS-485</b> .....	Serial standard interface
<b>SD</b> .....	Secure Digital memory card
<b>SIM</b> .....	Subscriber Identity Module (Card) used to store information in mobile phones
<b>SoC</b> .....	System on a Chip means the integration of all or a large part of the functions of a programmable electronic system on a single chip
<b>SODIMM</b> .....	Small Outline Dual Inline Memory Module
<b>SSD</b> .....	Solid State Drive
<b>USB</b> .....	Universal Serial Bus
<b>Watchdog</b> .....	A watchdog (timer) is a computer hardware timing device that triggers a system reset if the main program hangs, in order to keep the computer running
<b>WLAN</b> .....	Wireless Local Area Network
<b>WWAN</b> .....	Wireless Wide Area Network

## Classified Index

<b>–A–</b>	
Advanced Menu .....	40
AMD CBS Menu .....	84
AMD PBS Menu.....	80
Assembly .....	11
Audio Connector .....	24
Audio Jack .....	26
<b>–B–</b>	
Battery Connector.....	23
BIOS .....	36
Boot Menu .....	74
<b>–D–</b>	
DDR4 RAM SODIMM Sockets .....	22
Dimensions of the board.....	16
Dual-USB 3.1 Gen2 Port .....	20
<b>–E–</b>	
eDP Connector .....	29
Entering Setup .....	36
Environmental Specification .....	9
Exit Menu .....	102
<b>–F–</b>	
FAN Connectors .....	32
Feature Connector.....	34
Feature Details .....	18
Feature Overview .....	7
<b>–G–</b>	
Gigabit Ethernet Dual-Port.....	20
<b>–J–</b>	
Jumpersetting for eDP Backlight .....	27
<b>–M–</b>	
M.2 Sockets .....	25
Main Menu .....	37
Mechanical Mounting.....	15
Mini-DP Connectors.....	19
<b>–P–</b>	
Power Button Connector.....	31
Power Button, Power and SATA LEDs.....	30
Power Connector .....	21
Power Menu.....	72
<b>–R–</b>	
Rear USB-C Port .....	26
Reset Connector.....	30
RS232/485 Connectors .....	33
<b>–S–</b>	
SATA Data Connector .....	28
SATA Power Connector.....	28
Security Menu.....	70
System Overview .....	10
<b>–U–</b>	
USB Internal Connector.....	35

